



# Better Code: Runtime Polymorphism

Sean Parent | Principal Scientist



**Bē**  
Natalie Shau

# Better Code

- Regular Types
  - Goal: No Incomplete Types
- Algorithms
  - Goal: No Raw Loops
- Data Structures
  - Goal: No Incidental Data Structures
- Runtime Polymorphism
  - Goal: No Inheritance
- Concurrency
  - Goal: No Raw Synchronization Primitives
- ...

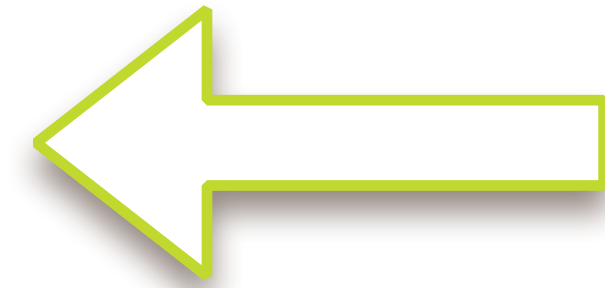

Goal: No inheritance

# What is inheritance?

*Inheritance* is a mechanism to implement runtime-polymorphism where one class is derived from another class, but overriding all or part of the implementation.

# Disclaimer

In the following code, the proper use of header files, inline functions, and namespaces are ignored for clarity

client

library

```
int main()  
{  
    cout << "Hello World!" << endl;  
}
```

cout

guidelines

defects

```
using object_t = int;
```

```
void draw(const object_t& x, ostream& out, size_t position)  
{ out << string(position, ' ') << x << endl; }
```

```
using document_t = vector<object_t>;
```

```
void draw(const document_t& x, ostream& out, size_t position)  
{  
    out << string(position, ' ') << "<document>" << endl;  
    for (const auto& e: x) draw(e, out, position + 2);  
    out << string(position, ' ') << "</document>" << endl;  
}
```

client

library

```
int main()
{
    document_t document;

    document.emplace_back(0);
    document.emplace_back(1);
    document.emplace_back(2);
    document.emplace_back(3);

    draw(document, cout, 0);
}
```

cout

guidelines

defects



# Runtime Polymorphism

- What happens if we want the document to hold any drawable object?

# Runtime Polymorphism

my\_class\_t : object\_t

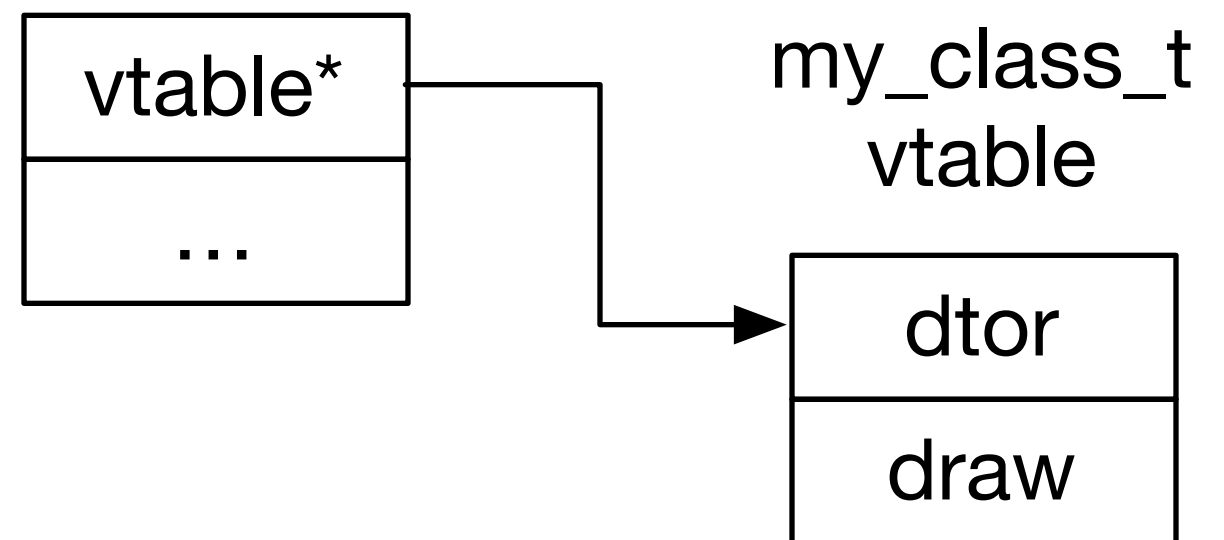

# Runtime Polymorphism

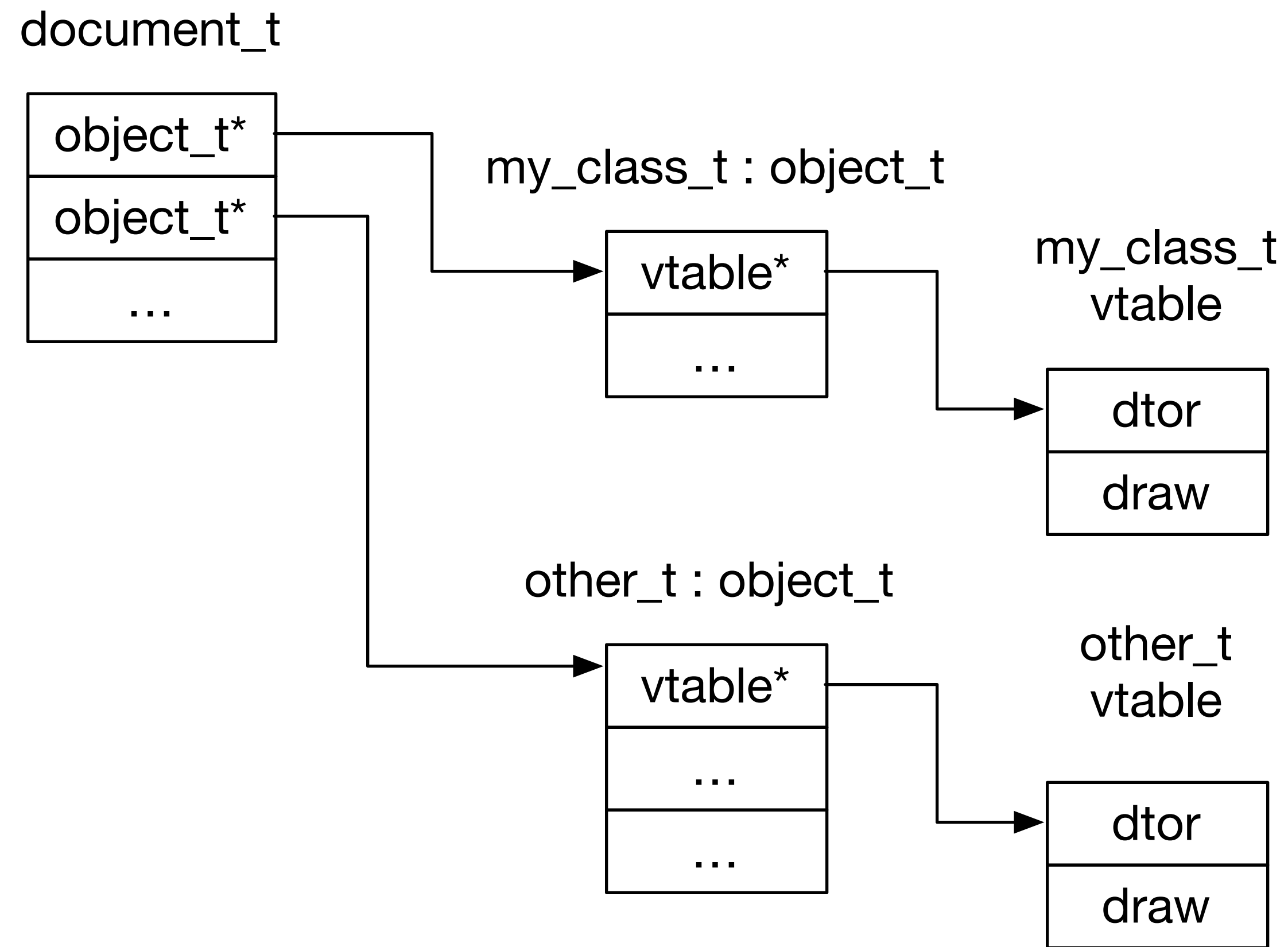

```
class object_t {  
public:  
    virtual ~object_t() { }  
    virtual void draw(ostream&, size_t) const = 0;  
};
```

```
using document_t = vector<shared_ptr<object_t>>;
```

```
void draw(const document_t& x, ostream& out, size_t position)  
{  
    out << string(position, ' ') << "<document>" << endl;  
    for (const auto& e: x) e->draw(out, position + 2);  
    out << string(position, ' ') << "</document>" << endl;  
}
```

```
class my_class_t final : public object_t
{
public:
    void draw(ostream& out, size_t position) const override
    { out << string(position, ' ') << "my_class_t" << endl; }
    /* ... */
};

int main()
{
    document_t document;
    document.emplace_back(make_shared<my_class_t>());
    draw(document, cout, 0);
}
```

# Deep problem #1

- Changed semantics of copy, assignment, and equality of my document
  - leads to *incidental data-structures*
  - thread safety concerns

# Semantics & Syntax

- We define an operation in terms of the operation's semantics:

*“Assignment is a procedure taking two objects of the same type that makes the first object equal to the second without modifying the second.” – Elements of Programming, Section 1.5*

# Semantics & Syntax

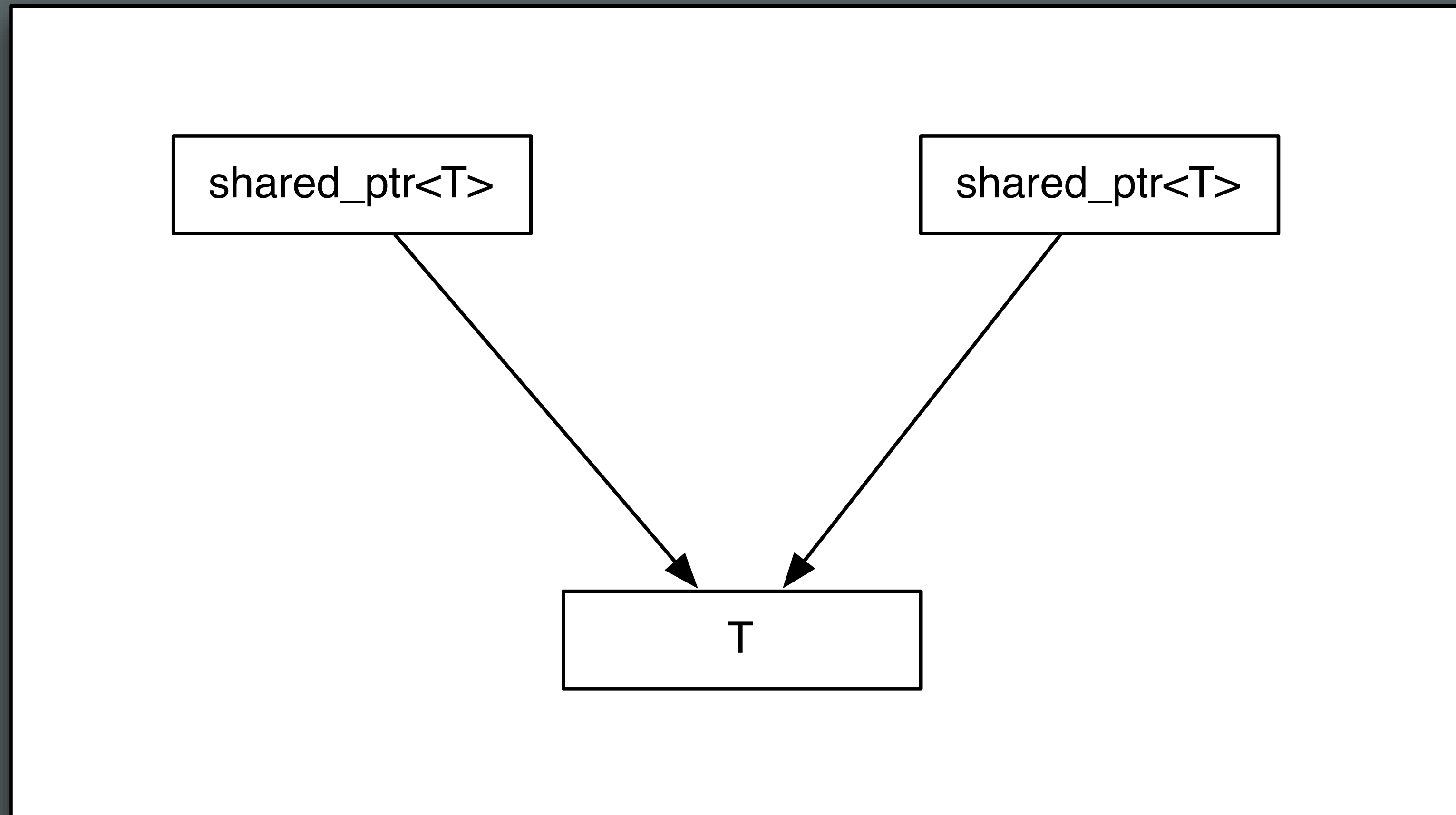



# Semantics & Syntax

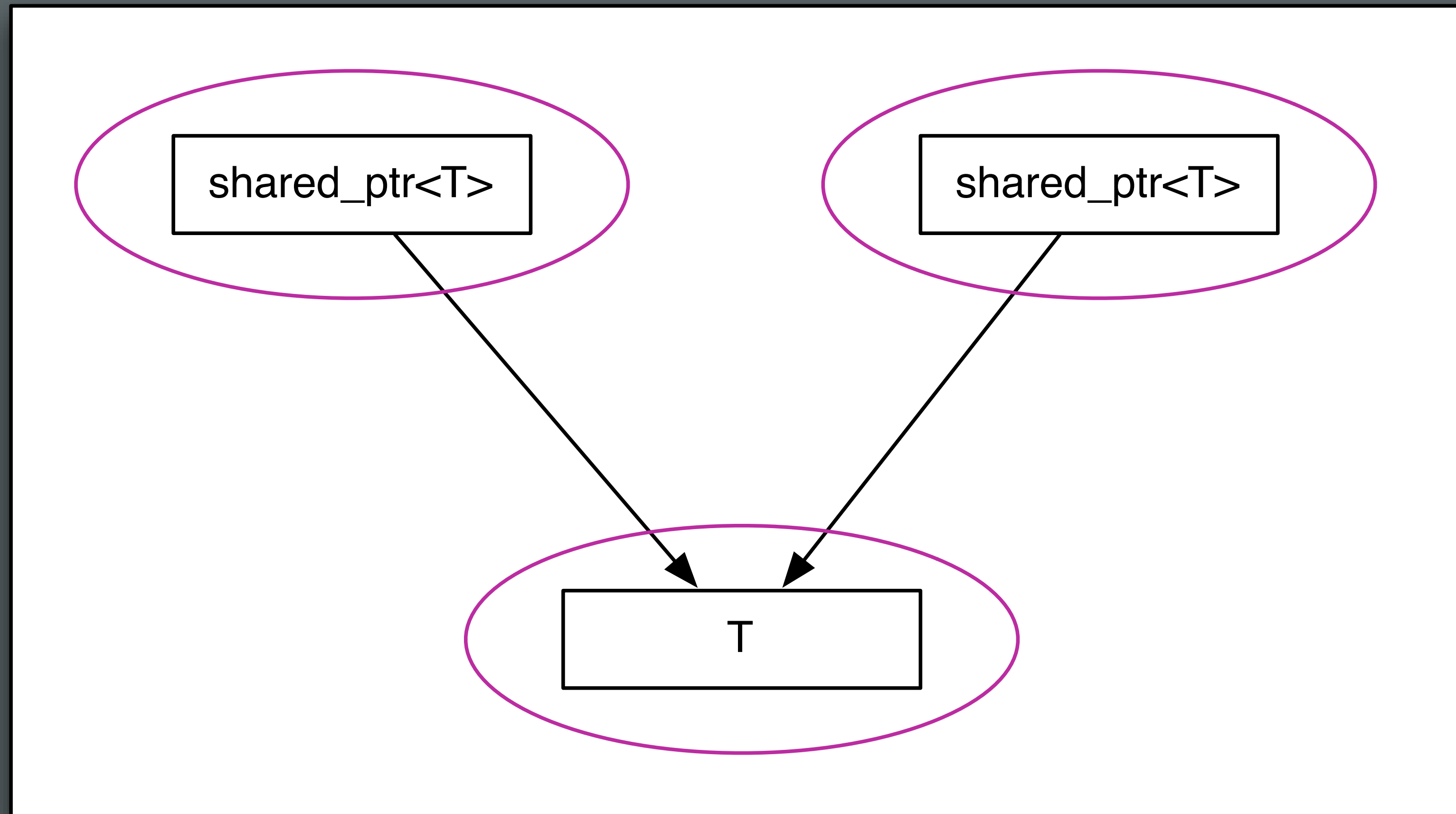

# Semantics & Syntax

- Considered as individual types, assignment and copy hold their regular semantic meanings
  - However, this fails to account for the relationships (the arrows) which form an incidental data-structure. You cannot operate on T through one of the shared pointers without considering the effect on the other shared pointer

# Semantics & Syntax

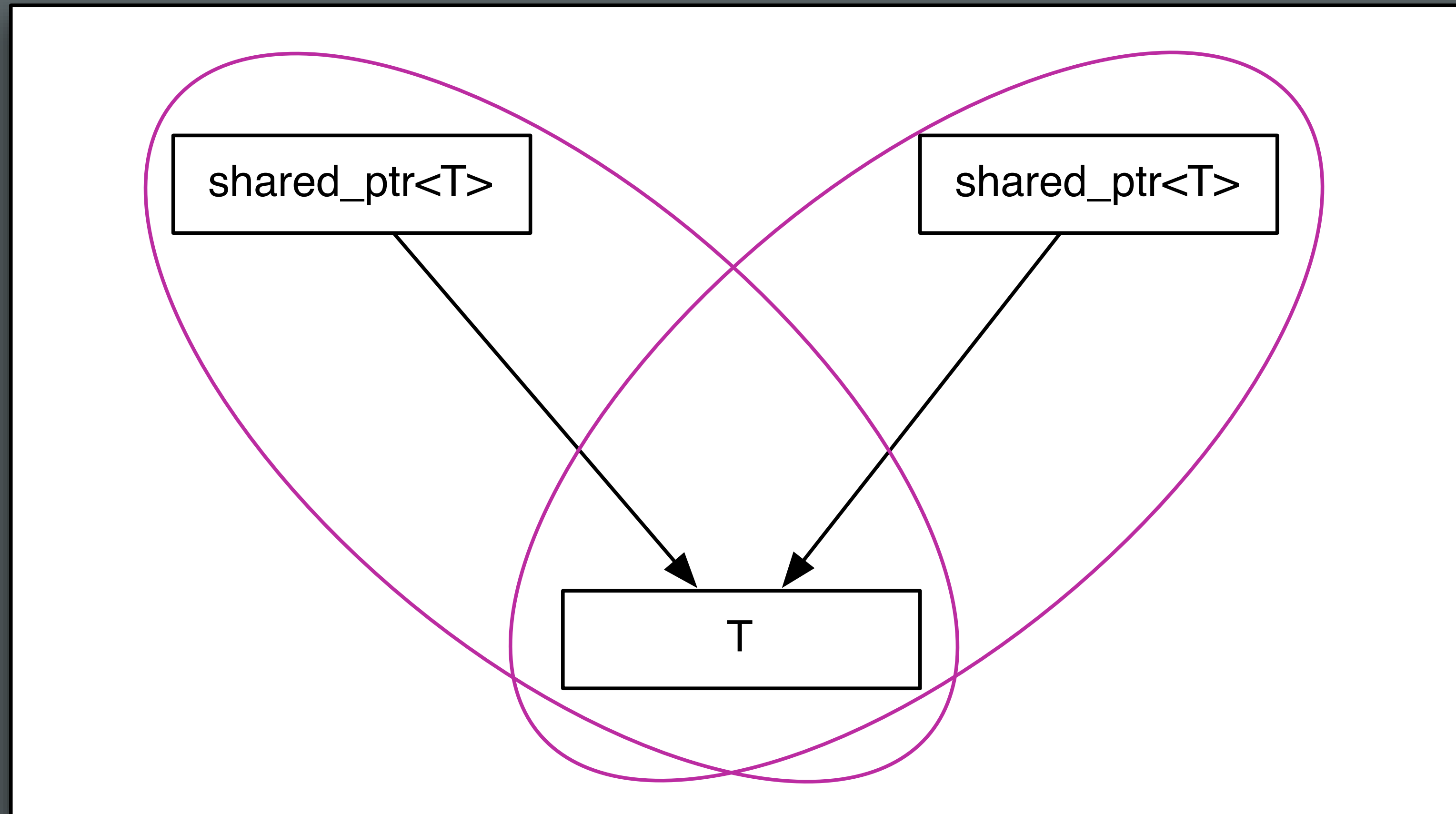

# Semantics & Syntax

- If we extend our notion of object type to include the directly related part then we have intersecting objects which will interfere with each other

# Semantics & Syntax

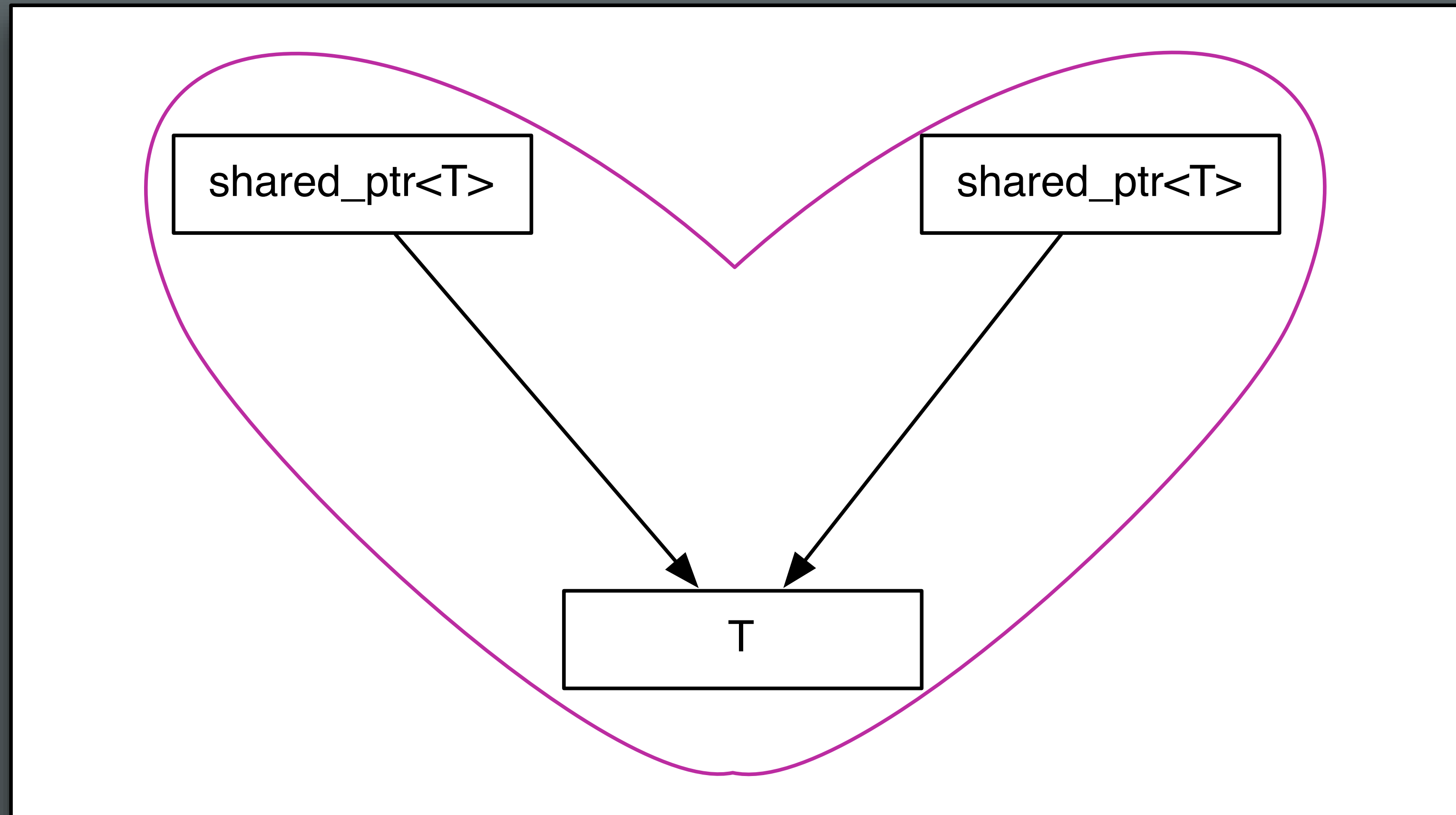

# Semantics & Syntax

- When we consider the whole, the standard syntax for copy and assignment no longer have their regular semantics.
  - This structure is still copyable and assignable but these operations must be done through other means
- The shared structure also breaks our ability to reason locally about the code

**A shared pointer is as good as a global variable**

# Semantics & Syntax

- Choosing the same syntax for the same semantics enables code reuse and avoids combinatoric interfaces
  - If a type has a proper set of basis operations then it can be adapted to any alternative set of basis operations regardless of syntax
- C++ has defined semantics for operations on built-in types, including assignment, copy, equality, address-of
  - Using the same operator names to provide the same semantics on user types enables code reuse

# Regular Types

“There is a set of procedures whose inclusion in the computational basis of a type lets us place objects in data structures and use algorithms to copy objects from one data structure to another. We call types having such a basis *regular*, since their use guarantees regularity of behavior and, therefore, interoperability.” – *Elements of Programming, Section 1.5*



# Semantics & Syntax

- Regular types where the regular operations are implemented with the standard names are said to have *value semantics*
- When objects are referred to indirectly, through a shared reference or pointer, the objects are said to have *reference semantics*

# Deep problem #2

- Inefficient
  - calls to draw() on my\_class\_t are often indirect through virtual calls, including the destructor
  - my\_class\_t is *always* heap allocated
  - access to my class\_t must be synchronized

# Deep problem #3

- Polymorphism is intrusive
  - Document can no longer hold a drawable integer

# “Polymorphic Types”

- The requirement of a polymorphic type, by definition, comes from its use
- There are no polymorphic types, only a *polymorphic use* of similar types

# “Polymorphic Types”

- By using inheritance to capture polymorphic use, we shift the burden of use to the type implementation, tightly coupling components
- Inheritance implies variable size, which implies heap allocation
- Heap allocation forces a further burden to manage the object lifetime
- Indirection, heap allocation, and virtualization, impacts performance
- Object lifetime management leads to garbage collection or reference counting
- This encourages *shared* ownership and the proliferation of *incidental data-structures*
- Shared ownership leads to synchronization issues, breaks local reasoning, and further impacts performance

**Inheritance is the base class of Evil**

```
using object_t = int;
```

```
void draw(const object_t& x, ostream& out, size_t position)  
{ out << string(position, ' ') << x << endl; }
```

```
using document_t = vector<object_t>;
```

```
void draw(const document_t& x, ostream& out, size_t position)  
{  
    out << string(position, ' ') << "<document>" << endl;  
    for (const auto& e: x) draw(e, out, position + 2);  
    out << string(position, ' ') << "</document>" << endl;  
}
```

```
using object_t = int;
```

```
void draw(const object_t& x, ostream& out, size_t position)
{ out << string(position, ' ') << x << endl; }
```

```
using document_t = vector<object_t>;
```

```
void draw(const document_t& x, ostream& out, size_t position)
{
    out << string(position, ' ') << "<document>" << endl;
    for (const auto& e: x) draw(e, out, position + 2);
    out << string(position, ' ') << "</document>" << endl;
}
```

```
void draw(const int& x, ostream& out, size_t position)
{ out << string(position, ' ') << x << endl; }

class object_t {
public:
    object_t(const int& x) : self_(x)
    { }

    friend void draw(const object_t& x, ostream& out, size_t position)
    { draw(x.self_, out, position); }

private:
    int self_;
};
```

```
using document_t = vector<object_t>;
```

```
void draw(const document_t& x, ostream& out, size_t position)
{
    out << string(position, ' ') << "<document>" << endl;
    for (const auto& e: x) draw(e, out, position + 2);
    out << string(position, ' ') << "</document>" << endl;
}
```



client

library

```
int main()
{
    document_t document;

    document.emplace_back(0);
    document.emplace_back(1);
    document.emplace_back(2);
    document.emplace_back(3);

    draw(document, cout, 0);
}
```

cout

guidelines

defects

```
void draw(const int& x, ostream& out, size_t position)
{ out << string(position, ' ') << x << endl; }

class object_t {
public:
    object_t(const int& x) : self_(x)
    { }

    friend void draw(const object_t& x, ostream& out, size_t position)
    { draw(x.self_, out, position); }

private:
    int self_;
};

using document_t = vector<object_t>;

void draw(const document_t& x, ostream& out, size_t position)
{
    out << string(position, ' ') << "<document>" << endl;
    for (const auto& e: x) draw(e, out, position + 2);
    out << string(position, ' ') << "</document>" << endl;
}
```

client

library

```
{ out << string(position, ' ') << x << endl; }
```

```
class object_t {  
public:  
    object_t(const int& x) : self_(x)  
    { }  
  
    friend void draw(const object_t& x, ostream& out, size_t position)  
    { draw(x.self_, out, position); }  
  
private:  
    int self_;  
};  
  
using document_t = vector<object_t>;  
  
void draw(const document_t& x, ostream& out, size_t position)  
{  
    out << string(position, ' ') << "<document>" << endl;  
    for (const auto& e: x) draw(e, out, position + 2);  
    out << string(position, ' ') << "</document>" << endl;  
}
```

cout

guidelines

defects

client

library



```
class object_t {
public:
    object_t(const int& x) : self_(x)
    { }

    friend void draw(const object_t& x, ostream& out, size_t position)
    { draw(x.self_, out, position); }

private:
    int self_;
};

using document_t = vector<object_t>;

void draw(const document_t& x, ostream& out, size_t position)
{
    out << string(position, ' ') << "<document>" << endl;
    for (const auto& e: x) draw(e, out, position + 2);
    out << string(position, ' ') << "</document>" << endl;
}
```

cout

guidelines

defects

client

library

```
class object_t {  
    public:  
        object_t(const int& x) : self_(x)  
        { }  
  
        friend void draw(const object_t& x, ostream& out, size_t position)  
        { draw(x.self_, out, position); }  
  
    private:  
        int self_;  
};  
  
using document_t = vector<object_t>;  
  
void draw(const document_t& x, ostream& out, size_t position)  
{  
    out << string(position, ' ') << "<document>" << endl;  
    for (const auto& e: x) draw(e, out, position + 2);  
    out << string(position, ' ') << "</document>" << endl;  
}
```

cout

guidelines

defects

```
class object_t {  
    public:  
        object_t(const int& x) : self_(x)  
        { }  
  
        friend void draw(const object_t& x, ostream& out, size_t position)  
        { draw(x.self_, out, position); }  
  
    private:  
        int self_;  
};
```

```
using document_t = vector<object_t>;
```

```
void draw(const document_t& x, ostream& out, size_t position)  
{  
    out << string(position, ' ') << "<document>" << endl;  
    for (const auto& e: x) draw(e, out, position + 2);  
    out << string(position, ' ') << "</document>" << endl;  
}
```

```
class object_t {  
public:  
    object_t(const int& x) : self_(make_unique<int_model_t>(x))  
    { }  
  
    friend void draw(const object_t& x, ostream& out, size_t position)  
    { x.self_>draw_(out, position); }  
  
private:  
    struct int_model_t {  
        int_model_t(const int& x) : data_(x) { }  
        void draw_(ostream& out, size_t position) const  
        { draw(data_, out, position); }  
  
        int data_;  
    };  
  
    unique_ptr<int_model_t> self_;  
};
```

```
using document_t = vector<object_t>;
```

```
void draw(const document_t& x, ostream& out, size_t position)  
{  
    out << string(position, ' ') << "<document>" << endl;
```

```
class object_t {  
    public:  
        object_t(const int& x) : self_(make_unique<int_model_t>(x))  
        { }  
  
        object_t(const object_t& x) : self_(make_unique<int_model_t>(*x.self_))  
        { }  
  
        friend void draw(const object_t& x, ostream& out, size_t position)  
        { x.self_>draw_(out, position); }  
  
    private:  
        struct int_model_t {  
            int_model_t(const int& x) : data_(x) { }  
            void draw_(ostream& out, size_t position) const  
            { draw(data_, out, position); }  
  
            int data_;  
        };  
  
        unique_ptr<int_model_t> self_;  
};  
  
using document_t = vector<object_t>;
```



```
class object_t {  
    public:  
        object_t(const int& x) : self_(make_unique<int_model_t>(x))  
        { }  
  
        object_t(const object_t& x) : self_(make_unique<int_model_t>(*x.self_))  
        { }  
  
        object_t& operator=(const object_t& x)  
        { object_t tmp(x); self_ = move(tmp.self_); return *this; }  
  
        friend void draw(const object_t& x, ostream& out, size_t position)  
        { x.self_>draw_(out, position); }  
  
    private:  
        struct int_model_t {  
            int_model_t(const int& x) : data_(x) { }  
            void draw_(ostream& out, size_t position) const  
            { draw(data_, out, position); }  
  
            int data_;  
        };  
  
        unique_ptr<int_model_t> self_;  
};
```

client

library

```
int main()
{
    document_t document;

    document.emplace_back(0);
    document.emplace_back(1);
    document.emplace_back(2);
    document.emplace_back(3);

    draw(document, cout, 0);
}
```

cout

guidelines

defects

```
class object_t {  
    public:  
        object_t(const int& x) : self_(make_unique<int_model_t>(x))  
        { }  
  
        object_t(const object_t& x) : self_(make_unique<int_model_t>(*x.self_))  
        { }  
  
        object_t& operator=(const object_t& x)  
        { object_t tmp(x); *this = move(tmp); return *this; }  
  
        friend void draw(const object_t& x, ostream& out, size_t position)  
        { x.self_>draw_(out, position); }  
  
    private:  
        struct int_model_t {  
            int_model_t(const int& x) : data_(x) { }  
            void draw_(ostream& out, size_t position) const  
            { draw(data_, out, position); }  
  
            int data_;  
        };  
  
        unique_ptr<int_model_t> self_;  
};
```

```
class object_t {  
    public:  
        object_t(const int& x) : self (make_unique<int_model_t>(x))  
        { cout << "ctor" << endl; }  
  
        object_t(const object_t& x) : self (make_unique<int_model_t>(*x.self ))  
        { cout << "copy" << endl; }  
        object_t& operator=(const object_t& x)  
        { object_t tmp(x); *this = move(tmp); return *this; }  
  
        friend void draw(const object_t& x, ostream& out, size_t position)  
        { x.self_>draw_(out, position); }  
  
    private:  
        struct int_model_t {  
            int_model_t(const int& x) : data_(x) { }  
            void draw_(ostream& out, size_t position) const  
            { draw(data_, out, position); }  
  
            int data_;  
        };  
  
        unique_ptr<int_model_t> self_;  
};
```

```
object_t func()
{
    object_t result = 5;
    return result;
}

int main()
{
    /*
     * Quiz: What will this print?
     */

    object_t x = func();
}
```

```
object_t func()
{
    object_t result = 5;
    return result;
}

int main()
{
    /*
     * Quiz: What will this print?
     */
    object_t x = 0;
    x = func();
}
```

```
class object_t {  
    public:  
        object_t(const int& x) : self_(make_unique<int_model_t>(x))  
        { cout << "ctor" << endl; }  
  
        object_t(const object_t& x) : self_(make_unique<int_model_t>(*x.self_))  
        { cout << "copy" << endl; }  
        object_t& operator=(const object_t& x)  
        { object_t tmp(x); self_ = move(tmp.self_); return *this; }  
  
        friend void draw(const object_t& x, ostream& out, size_t position)  
        { x.self_>draw_(out, position); }  
  
    private:  
        struct int_model_t {  
            int_model_t(const int& x) : data_(x) { }  
            void draw_(ostream& out, size_t position) const  
            { draw(data_, out, position); }  
  
            int data_;  
        };  
  
        unique_ptr<int_model_t> self_;  
};
```

```
class object_t {  
    public:  
        object_t(const int& x) : self_(make_unique<int_model_t>(x))  
        { cout << "ctor" << endl; }  
  
        object_t(const object_t& x) : self_(make_unique<int_model_t>(*x.self_))  
        { cout << "copy" << endl; }  
        object_t& operator=(object_t x) noexcept  
        { self_ = move(x.self_); return *this; }  
  
        friend void draw(const object_t& x, ostream& out, size_t position)  
        { x.self_>draw_(out, position); }  
  
    private:  
        struct int_model_t {  
            int_model_t(const int& x) : data_(x) { }  
            void draw_(ostream& out, size_t position) const  
            { draw(data_, out, position); }  
  
            int data_;  
        };  
  
        unique_ptr<int_model_t> self_;  
};
```



```
object_t func()
{
    object_t result = 5;
    return result;
}

int main()
{
    /*
     * Quiz: What will this print?
     */

    object_t x = 0;

    x = func();
}
```

client

library

```
int main()
{
    document_t document;
    document.reserve(5);

    document.emplace_back(0);
    document.emplace_back(1);
    document.emplace_back(2);
    document.emplace_back(3);

    reverse(document.begin(), document.end());

    draw(document, cout, 0);
}
```

cout

guidelines

defects

```
class object_t {  
    public:  
        object_t(const int& x) : self_(make_unique<int_model_t>(x))  
        { cout << "ctor" << endl; }  
  
        object_t(const object_t& x) : self_(make_unique<int_model_t>(*x.self_))  
        { cout << "copy" << endl; }  
        object_t(object_t&& x) noexcept : self_(move(x.self_)) { }  
        object_t& operator=(object_t x) noexcept  
        { self_ = move(x.self_); return *this; }  
  
        friend void draw(const object_t& x, ostream& out, size_t position)  
        { x.self_>draw_(out, position); }  
  
    private:  
        struct int_model_t {  
            int_model_t(const int& x) : data_(x) { }  
            void draw_(ostream& out, size_t position) const  
            { draw(data_, out, position); }  
  
            int data_;  
        };  
  
        unique_ptr<int_model_t> self_;  
};
```

```
class object_t {  
    public:  
        object_t(const int& x) : self_(make_unique<int_model_t>(x))  
        { cout << "ctor" << endl; }  
  
        object_t(const object_t& x) : self_(make_unique<int_model_t>(*x.self_))  
        { cout << "copy" << endl; }  
        object_t(object_t&&) noexcept = default;  
        object_t& operator=(object_t x) noexcept  
        { self_ = move(x.self_); return *this; }  
  
        friend void draw(const object_t& x, ostream& out, size_t position)  
        { x.self_>draw_(out, position); }  
  
    private:  
        struct int_model_t {  
            int_model_t(const int& x) : data_(x) { }  
            void draw_(ostream& out, size_t position) const  
            { draw(data_, out, position); }  
  
            int data_;  
        };  
  
        unique_ptr<int_model_t> self_;  
};
```

```
int main()
{
    document_t document;
    document.reserve(5);

    document.emplace_back(0);
    document.emplace_back(1);
    document.emplace_back(2);
    document.emplace_back(3);

    reverse(document.begin(), document.end());

    draw(document, cout, 0);
}
```

```
struct some_t {  
    object_t member_;  
};  
  
some_t func() { return { 5 }; }  
  
int main()  
{  
    /*  
     * Quiz: What will this print?  
     */  
    some_t x = { 0 };  
    x = func();  
}
```

```
class object_t {  
    public:  
        object_t(const int& x) : self_(make_unique<int_model_t>(x))  
        { cout << "ctor" << endl; }  
  
        object_t(const object_t& x) : self_(make_unique<int_model_t>(*x.self_))  
        { cout << "copy" << endl; }  
        object_t(object_t&&) noexcept = default;  
        object_t& operator=(object_t x)  
        { self_ = move(x.self_); return *this; }  
  
        friend void draw(const object_t& x, ostream& out, size_t position)  
        { x.self_>draw_(out, position); }  
  
    private:  
        struct int_model_t {  
            int_model_t(const int& x) : data_(x) { }  
            void draw_(ostream& out, size_t position) const  
            { draw(data_, out, position); }  
  
            int data_;  
        };  
  
        unique_ptr<int_model_t> self_;  
};
```

```
class object_t {  
    public:  
        object_t(const int& x) : self_(make_unique<int_model_t>(x))  
        { cout << "ctor" << endl; }  
  
        object_t(const object_t& x) : self_(make_unique<int_model_t>(*x.self_))  
        { cout << "copy" << endl; }  
        object_t(object_t&&) noexcept = default;  
  
        object_t& operator=(const object_t& x)  
        { object_t tmp(x); *this = move(tmp); return *this; }  
        object_t& operator=(object_t&&) noexcept = default;  
  
        friend void draw(const object_t& x, ostream& out, size_t position)  
        { x.self_>draw_(out, position); }  
  
    private:  
        struct int_model_t {  
            int_model_t(const int& x) : data_(x) { }  
            void draw_(ostream& out, size_t position) const  
            { draw(data_, out, position); }  
  
            int data_;  
        };  
};
```



```
struct some_t {
    object_t member_;
};

some_t func() { return { 5 }; }

int main()
{
    /*
     * Quiz: What will this print?
     */
    some_t x = { 0 };

    x = func();
}
```

# Keypoint

- Returning objects from functions, passing read-only arguments, and passing rvalues as sink arguments do not require copying
- Understanding this can greatly improve the efficiency of your application

```
class object_t {  
    public:  
        object_t(const int& x) : self_(make_unique<int_model_t>(x))  
        { cout << "ctor" << endl; }  
  
        object_t(const object_t& x) : self_(make_unique<int_model_t>(*x.self_))  
        { cout << "copy" << endl; }  
        object_t(object_t&&) noexcept = default;  
  
        object_t& operator=(const object_t& x)  
        { object_t tmp(x); *this = move(tmp); return *this; }  
        object_t& operator=(object_t&&) noexcept = default;  
  
        friend void draw(const object_t& x, ostream& out, size_t position)  
        { x.self_>draw_(out, position); }  
  
    private:  
        struct int_model_t {  
            int_model_t(const int& x) : data_(x) { }  
            void draw_(ostream& out, size_t position) const  
            { draw(data_, out, position); }  
  
            int data_;  
        };  
};
```

```
class object_t {  
    public:  
        object_t(const int& x) : self (make_unique<int model t>(x))  
        { }  
  
        object_t(const object_t& x) : self (make_unique<int model t>(*x.self ))  
        { }  
        object_t(object_t&&) noexcept = default;  
  
        object_t& operator=(const object_t& x)  
        { object_t tmp(x); *this = move(tmp); return *this; }  
        object_t& operator=(object_t&&) noexcept = default;  
  
        friend void draw(const object_t& x, ostream& out, size_t position)  
        { x.self_>draw_(out, position); }  
  
    private:  
        struct int_model_t {  
            int_model_t(const int& x) : data_(x) { }  
            void draw_(ostream& out, size_t position) const  
            { draw(data_, out, position); }  
  
            int data_;  
        };  
};
```

```
class object_t {  
    public:  
        object_t(const int& x) : self_(make_unique<int_model_t>(x))  
        { }  
  
        object_t(const object_t& x) : self_(make_unique<int_model_t>(*x.self_))  
        { }  
        object_t(object_t&&) noexcept = default;  
  
        object_t& operator=(const object_t& x)  
        { object_t tmp(x); *this = move(tmp); return *this; }  
        object_t& operator=(object_t&&) noexcept = default;  
  
        friend void draw(const object_t& x, ostream& out, size_t position)  
        { x.self_>draw_(out, position); }  
  
    private:  
        struct int_model_t {  
            int_model_t(const int& x) : data_(x) { }  
            void draw_(ostream& out, size_t position) const  
            { draw(data_, out, position); }  
  
            int data_;  
        };  
};
```

```
class object_t {  
    public:  
    object_t(const int& x) : self_(make_unique<int_model_t>(x))  
    { }  
  
    object_t(const object_t& x) : self_(make_unique<int_model_t>(*x.self_))  
    { }  
    object_t(object_t&&) noexcept = default;  
  
    object_t& operator=(const object_t& x)  
    { object_t tmp(x); *this = move(tmp); return *this; }  
    object_t& operator=(object_t&&) noexcept = default;  
  
    friend void draw(const object_t& x, ostream& out, size_t position)  
    { x.self_>draw_(out, position); }  
  
    private:  
    struct int_model_t {  
        int_model_t(const int& x) : data_(x) { }  
        void draw_(ostream& out, size_t position) const  
        { draw(data_, out, position); }  
  
        int data_;  
    };  
};
```

```
class object_t {  
    public:  
    object_t(int x) : self_(make_unique<int_model_t>(move(x)))  
    { }  
  
    object_t(const object_t& x) : self_(make_unique<int_model_t>(*x.self_))  
    { }  
    object_t(object_t&&) noexcept = default;  
  
    object_t& operator=(const object_t& x)  
    { object_t tmp(x); *this = move(tmp); return *this; }  
    object_t& operator=(object_t&&) noexcept = default;  
  
    friend void draw(const object_t& x, ostream& out, size_t position)  
    { x.self_>draw_(out, position); }  
  
    private:  
    struct int_model_t {  
        int_model_t(int x) : data_(move(x)) { }  
        void draw_(ostream& out, size_t position) const  
        { draw(data_, out, position); }  
  
        int data_;  
    };  
};
```

```
class object_t {  
    public:  
        object_t(int x) : self_(make_unique<int_model_t>(move(x)))  
        { }  
  
        object_t(const object_t& x) : self_(make_unique<int_model_t>(*x.self_))  
        { }  
        object_t(object_t&&) noexcept = default;  
  
        object_t& operator=(const object_t& x)  
        { object_t tmp(x); *this = move(tmp); return *this; }  
        object_t& operator=(object_t&&) noexcept = default;  
  
        friend void draw(const object_t& x, ostream& out, size_t position)  
        { x.self_>draw_(out, position); }  
  
    private:  
        struct int_model_t {  
            int_model_t(int x) : data_(move(x)) { }  
            void draw_(ostream& out, size_t position) const  
            { draw(data_, out, position); }  
  
            int data_;  
        };  
};
```



public:

```
object_t(string x) : self_(make_unique<string_model_t>(move(x)))  
{ }
```

```
object_t(int x) : self_(make_unique<int_model_t>(move(x)))  
{ }
```

```
object_t(const object_t& x) : self_(make_unique<int_model_t>(*x.self_))  
{ }
```

```
object_t(object_t&&) noexcept = default;
```

```
object_t& operator=(const object_t& x)  
{ object_t tmp(x); *this = move(tmp); return *this; }  
object_t& operator=(object_t&&) noexcept = default;
```

```
friend void draw(const object_t& x, ostream& out, size_t position)  
{ x.self_>draw_(out, position); }
```

private:

```
struct string_model_t {  
    string_model_t(string x) : data_(move(x)) { }  
    void draw_(ostream& out, size_t position) const  
    { draw(data_, out, position); }  
  
    string data_;  
};
```

```
public:
    object_t(string x) : self_(make_unique<string_model_t>(move(x)))
    { }
    object_t(int x) : self_(make_unique<int_model_t>(move(x)))
    { }

    object_t(const object_t& x) : self_(make_unique<int_model_t>(*x.self_))
    { }
    object_t(object_t&&) noexcept = default;

    object_t& operator=(const object_t& x)
    { object_t tmp(x); *this = move(tmp); return *this; }
    object_t& operator=(object_t&&) noexcept = default;

    friend void draw(const object_t& x, ostream& out, size_t position)
    { x.self_>draw_(out, position); }

private:
    struct string_model_t {
        string_model_t(string x) : data_(move(x)) { }
        void draw_(ostream& out, size_t position) const
        { draw(data_, out, position); }

        string data_;
    };
```

```
object_t(string x) : self_(make_unique<string_model_t>(move(x)))
{ }
object_t(int x) : self_(make_unique<int_model_t>(move(x)))
{ }

object_t(const object_t& x) : self_(make_unique<int_model_t>(*x.self_))
{ }
object_t(object_t&&) noexcept = default;

object_t& operator=(const object_t& x)
{ object_t tmp(x); *this = move(tmp); return *this; }
object_t& operator=(object_t&&) noexcept = default;

friend void draw(const object_t& x, ostream& out, size_t position)
{ x.self_>draw_(out, position); }

private:
struct string_model_t {
    string_model_t(string x) : data_(move(x)) { }
    void draw_(ostream& out, size_t position) const
    { draw(data_, out, position); }

    string data_;
};
struct int_model_t {
```

```
{ }
object_t(int x) : self_(make_unique<int_model_t>(move(x)))
{ }

object_t(const object_t& x) : self_(make_unique<int_model_t>(*x.self_))
{ }
object_t(object_t&&) noexcept = default;

object_t& operator=(const object_t& x)
{ object_t tmp(x); *this = move(tmp); return *this; }
object_t& operator=(object_t&&) noexcept = default;

friend void draw(const object_t& x, ostream& out, size_t position)
{ x.self_>draw_(out, position); }

private:
struct string_model_t {
    string_model_t(string x) : data_(move(x)) { }
    void draw_(ostream& out, size_t position) const
    { draw(data_, out, position); }

    string data_;
};
struct int_model_t {
    int_model_t(int x) : data_(move(x)) { }
```

client

library

```
object_t(int x) : self_(make_unique<int_model_t>(move(x)))
{ }

object_t(const object_t& x) : self_(make_unique<int_model_t>(*x.self_))
{ }
object_t(object_t&&) noexcept = default;

object_t& operator=(const object_t& x)
{ object_t tmp(x); *this = move(tmp); return *this; }
object_t& operator=(object_t&&) noexcept = default;

friend void draw(const object_t& x, ostream& out, size_t position)
{ x.self_>draw_(out, position); }

private:
struct string_model_t {
    string_model_t(string x) : data_(move(x)) { }
    void draw_(ostream& out, size_t position) const
    { draw(data_, out, position); }

    string data_;
};
struct int_model_t {
    int_model_t(int x) : data_(move(x)) { }
    void draw_(ostream& out, size_t position) const
```

cout

guidelines

defects

client

library

```
{ }  
  
object_t(const object_t& x) : self_(make_unique<int_model_t>(*x.self_))  
{ }  
object_t(object_t&&) noexcept = default;  
  
object_t& operator=(const object_t& x)  
{ object_t tmp(x); *this = move(tmp); return *this; }  
object_t& operator=(object_t&&) noexcept = default;  
  
friend void draw(const object_t& x, ostream& out, size_t position)  
{ x.self_>draw_(out, position); }  
  
private:  
struct string_model_t {  
    string_model_t(string x) : data_(move(x)) { }  
    void draw_(ostream& out, size_t position) const  
    { draw(data_, out, position); }  
  
    string data_;  
};  
struct int_model_t {  
    int_model_t(int x) : data_(move(x)) { }  
    void draw_(ostream& out, size_t position) const  
    { draw(data_, out, position); }
```

cout

guidelines

defects



```
object_t(const object_t& x) : self_(make_unique<int_model_t>(*x.self_))  
{ }  
object_t(object_t&&) noexcept = default;
```

```
object_t& operator=(const object_t& x)  
{ object_t tmp(x); *this = move(tmp); return *this; }  
object_t& operator=(object_t&&) noexcept = default;
```

```
friend void draw(const object_t& x, ostream& out, size_t position)  
{ x.self_>draw_(out, position); }
```

private:

```
struct string_model_t {  
    string_model_t(string x) : data_(move(x)) { }  
    void draw_(ostream& out, size_t position) const  
    { draw(data_, out, position); }
```

```
    string data_;
```

```
};
```

```
struct int_model_t {  
    int_model_t(int x) : data_(move(x)) { }  
    void draw_(ostream& out, size_t position) const  
    { draw(data_, out, position); }
```



client

library

```
object_t(const object_t& x) : self_(make_unique<int_model_t>(*x.self_))
{ }
object_t(object_t&&) noexcept = default;

object_t& operator=(const object_t& x)
{ object_t tmp(x); *this = move(tmp); return *this; }
object_t& operator=(object_t&&) noexcept = default;

friend void draw(const object_t& x, ostream& out, size_t position)
{ x.self_>draw_(out, position); }
```

private:

```
struct string_model_t {
    string_model_t(string x) : data_(move(x)) { }
    void draw_(ostream& out, size_t position) const
    { draw(data_, out, position); }

    string data_;
};
struct int_model_t {
    int_model_t(int x) : data_(move(x)) { }
    void draw_(ostream& out, size_t position) const
    { draw(data_, out, position); }

    int data_;
```

cout

guidelines

defects



client

library

```
{ }
object_t(object_t&&) noexcept = default;

object_t& operator=(const object_t& x)
{ object_t tmp(x); *this = move(tmp); return *this; }
object_t& operator=(object_t&&) noexcept = default;

friend void draw(const object_t& x, ostream& out, size_t position)
{ x.self_->draw_(out, position); }

private:
struct string_model_t {
    string_model_t(string x) : data_(move(x)) { }
    void draw_(ostream& out, size_t position) const
    { draw(data_, out, position); }

    string data_;
};
struct int_model_t {
    int_model_t(int x) : data_(move(x)) { }
    void draw_(ostream& out, size_t position) const
    { draw(data_, out, position); }

    int data_;
};
```

cout

guidelines

defects

```
object_t(object_t&&) noexcept = default;

object_t& operator=(const object_t& x)
{ object_t tmp(x); *this = move(tmp); return *this; }
object_t& operator=(object_t&&) noexcept = default;

friend void draw(const object_t& x, ostream& out, size_t position)
{ x.self_->draw_(out, position); }

private:
struct string_model_t {
    string_model_t(string x) : data_(move(x)) { }
    void draw_(ostream& out, size_t position) const
    { draw(data_, out, position); }

    string data_;
};
struct int_model_t {
    int_model_t(int x) : data_(move(x)) { }
    void draw_(ostream& out, size_t position) const
    { draw(data_, out, position); }

    int data_;
};
```



```
object_t& operator=(const object_t& x)
{ object_t tmp(x); *this = move(tmp); return *this; }
object_t& operator=(object_t&&) noexcept = default;

friend void draw(const object_t& x, ostream& out, size_t position)
{ x.self_>draw_(out, position); }
```

private:

```
struct string_model_t {
    string_model_t(string x) : data_(move(x)) { }
    void draw_(ostream& out, size_t position) const
    { draw(data_, out, position); }

    string data_;
};
struct int_model_t {
    int_model_t(int x) : data_(move(x)) { }
    void draw_(ostream& out, size_t position) const
    { draw(data_, out, position); }

    int data_;
};
```

```
unique_ptr<int_model_t> self_;
```



client

library

```
object_t& operator=(const object_t& x)
{ object_t tmp(x); *this = move(tmp); return *this; }
object_t& operator=(object_t&&) noexcept = default;

friend void draw(const object_t& x, ostream& out, size_t position)
{ x.self_>draw_(out, position); }
```

private:

```
struct string_model_t {
    string_model_t(string x) : data_(move(x)) { }
    void draw_(ostream& out, size_t position) const
    { draw(data_, out, position); }
```

```
    string data_;
```

```
};
```

```
struct int_model_t {
    int_model_t(int x) : data_(move(x)) { }
    void draw_(ostream& out, size_t position) const
    { draw(data_, out, position); }
```

```
    int data_;
```

```
};
```

```
unique_ptr<int_model_t> self_;
```

```
};
```

cout

guidelines

defects

```
object_t& operator=(const object_t& x)
{ object_t tmp(x); *this = move(tmp); return *this; }
object_t& operator=(object_t&&) noexcept = default;

friend void draw(const object_t& x, ostream& out, size_t position)
{ x.self_>draw_(out, position); }
```

private:

```
struct string_model_t {
    string_model_t(string x) : data_(move(x)) { }
    void draw_(ostream& out, size_t position) const
    { draw(data_, out, position); }

    string data_;
};
struct int_model_t {
    int_model_t(int x) : data_(move(x)) { }
    void draw_(ostream& out, size_t position) const
    { draw(data_, out, position); }

    int data_;
};
```

```
unique_ptr<int_model_t> self_;
```

```
};
```

```
object_t& operator=(const object_t& x)
{ object_t tmp(x); *this = move(tmp); return *this; }
object_t& operator=(object_t&&) noexcept = default;

friend void draw(const object_t& x, ostream& out, size_t position)
{ x.self_>draw_(out, position); }
```

private:

```
struct string_model_t {
    string_model_t(string x) : data_(move(x)) { }
    void draw_(ostream& out, size_t position) const
    { draw(data_, out, position); }

    string data_;
};
struct int_model_t {
    int_model_t(int x) : data_(move(x)) { }
    void draw_(ostream& out, size_t position) const
    { draw(data_, out, position); }

    int data_;
};
```

```
unique_ptr<concept_t> self_;
```

```
};
```

```
object_t& operator=(const object_t& x)
{ object_t tmp(x); *this = move(tmp); return *this; }
object_t& operator=(object_t&&) noexcept = default;

friend void draw(const object_t& x, ostream& out, size_t position)
{ x.self_>draw_(out, position); }
```

private:

```
struct string_model_t {
    string_model_t(string x) : data_(move(x)) { }
    void draw_(ostream& out, size_t position) const
    { draw(data_, out, position); }
```

```
    string data_;
```

```
};
```

```
struct int_model_t {
    int_model_t(int x) : data_(move(x)) { }
    void draw_(ostream& out, size_t position) const
    { draw(data_, out, position); }
```

```
    int data_;
```

```
};
```

```
unique_ptr<concept_t> self_;
```

```
};
```

```
object_t& operator=(const object_t& x)
{ object_t tmp(x); *this = move(tmp); return *this; }
object_t& operator=(object_t&&) noexcept = default;

friend void draw(const object_t& x, ostream& out, size_t position)
{ x.self_>draw_(out, position); }
```

private:

```
struct concept_t {
    virtual ~concept_t() = default;
};
struct string_model_t final : concept_t {
    string_model_t(string x) : data_(move(x)) { }
    void draw_(ostream& out, size_t position) const
    { draw(data_, out, position); }

    string data_;
};
struct int_model_t final : concept_t {
    int_model_t(int x) : data_(move(x)) { }
    void draw_(ostream& out, size_t position) const
    { draw(data_, out, position); }

    int data_;
};
```



```
object_t& operator=(const object_t& x)
{ object_t tmp(x); *this = move(tmp); return *this; }
object_t& operator=(object_t&&) noexcept = default;

friend void draw(const object_t& x, ostream& out, size_t position)
{ x.self_>draw_(out, position); }
```

private:

```
struct concept_t {
    virtual ~concept_t() = default;
    virtual void draw_(ostream&, size_t) const = 0;
};

struct string_model_t final : concept_t {
    string model_t(string x) : data(move(x)) { }
    void draw_(ostream& out, size_t position) const override
    { draw(data_, out, position); }

    string data_;
};

struct int_model_t final : concept_t {
    int_model_t(int x) : data_(move(x)) { }
    void draw_(ostream& out, size_t position) const override
    { draw(data_, out, position); }

    int data_;
```

client

library

```
object_t& operator=(const object_t& x)
{ object_t tmp(x); *this = move(tmp); return *this; }
object_t& operator=(object_t&&) noexcept = default;

friend void draw(const object_t& x, ostream& out, size_t position)
{ x.self_->draw_(out, position); }
```

private:

```
struct concept_t {
    virtual ~concept_t() = default;
    virtual void draw_(ostream&, size_t) const = 0;
};

struct string_model_t final : concept_t {
    string_model_t(string x) : data_(move(x)) { }
    void draw_(ostream& out, size_t position) const override
    { draw(data_, out, position); }

    string data_;
};

struct int_model_t final : concept_t {
    int_model_t(int x) : data_(move(x)) { }
    void draw_(ostream& out, size_t position) const override
    { draw(data_, out, position); }

    int data_;
```

cout

guidelines

defects



```
object_t& operator=(const object_t& x)
{ object_t tmp(x); *this = move(tmp); return *this; }
object_t& operator=(object_t&&) noexcept = default;

friend void draw(const object_t& x, ostream& out, size_t position)
{ x.self_->draw_(out, position); }

private:
struct concept_t {
    virtual ~concept_t() = default;
    virtual void draw_(ostream&, size_t) const = 0;
};
struct string_model_t final : concept_t {
    string_model_t(string x) : data_(move(x)) { }
    void draw_(ostream& out, size_t position) const override
    { draw(data_, out, position); }

    string data_;
};
struct int_model_t final : concept_t {
    int_model_t(int x) : data_(move(x)) { }
    void draw_(ostream& out, size_t position) const override
    { draw(data_, out, position); }
```



client

library

```
object_t(object_t&&) noexcept = default;
```

```
object_t& operator=(const object_t& x)  
{ object_t tmp(x); *this = move(tmp); return *this; }  
object_t& operator=(object_t&&) noexcept = default;
```

```
friend void draw(const object_t& x, ostream& out, size_t position)  
{ x.self_>draw_(out, position); }
```

private:

```
struct concept_t {  
    virtual ~concept_t() = default;  
    virtual void draw_(ostream&, size_t) const = 0;  
};
```

```
struct string_model_t final : concept_t {  
    string_model_t(string x) : data_(move(x)) { }  
    void draw_(ostream& out, size_t position) const override  
    { draw(data_, out, position); }
```

```
    string data_;  
};
```

```
struct int_model_t final : concept_t {  
    int_model_t(int x) : data_(move(x)) { }  
    void draw_(ostream& out, size_t position) const override  
    { draw(data_, out, position); }
```

cout

guidelines

defects

client

library

```
{ }  
object_t(object_t&&) noexcept = default;  
  
object_t& operator=(const object_t& x)  
{ object_t tmp(x); *this = move(tmp); return *this; }  
object_t& operator=(object_t&&) noexcept = default;  
  
friend void draw(const object_t& x, ostream& out, size_t position)  
{ x.self_->draw_(out, position); }  
  
private:  
struct concept_t {  
    virtual ~concept_t() = default;  
    virtual void draw_(ostream&, size_t) const = 0;  
};  
struct string_model_t final : concept_t {  
    string_model_t(string x) : data_(move(x)) { }  
    void draw_(ostream& out, size_t position) const override  
    { draw(data_, out, position); }  
  
    string data_;  
};  
struct int_model_t final : concept_t {  
    int_model_t(int x) : data_(move(x)) { }  
    void draw_(ostream& out, size_t position) const override
```

cout

guidelines

defects

client

library

```
object_t(const object_t& x) : self_(make_unique<int_model_t>(*x.self_))
{ }
object_t(object_t&&) noexcept = default;

object_t& operator=(const object_t& x)
{ object_t tmp(x); *this = move(tmp); return *this; }
object_t& operator=(object_t&&) noexcept = default;

friend void draw(const object_t& x, ostream& out, size_t position)
{ x.self_>draw_(out, position); }
```

private:

```
struct concept_t {
    virtual ~concept_t() = default;
    virtual void draw_(ostream&, size_t) const = 0;
};
struct string_model_t final : concept_t {
    string_model_t(string x) : data_(move(x)) { }
    void draw_(ostream& out, size_t position) const override
    { draw(data_, out, position); }

    string data_;
};
struct int_model_t final : concept_t {
    int_model_t(int x) : data_(move(x)) { }
```

cout

guidelines

defects



```
object_t(const object_t& x) : self_(make_unique<int_model_t>(*x.self_))  
{ }  
object_t(object_t&&) noexcept = default;
```

```
object_t& operator=(const object_t& x)  
{ object_t tmp(x); *this = move(tmp); return *this; }  
object_t& operator=(object_t&&) noexcept = default;
```

```
friend void draw(const object_t& x, ostream& out, size_t position)  
{ x.self_>draw_(out, position); }
```

private:

```
struct concept_t {  
    virtual ~concept_t() = default;  
    virtual void draw_(ostream&, size_t) const = 0;  
};  
struct string_model_t final : concept_t {  
    string_model_t(string x) : data_(move(x)) { }  
    void draw_(ostream& out, size_t position) const override  
    { draw(data_, out, position); }  
  
    string data_;  
};  
struct int_model_t final : concept_t {
```

```
{ }  
  
object_t(const object_t& x) : self_(make_unique<int_model_t>(*x.self_))  
{ }  
object_t(object_t&&) noexcept = default;  
  
object_t& operator=(const object_t& x)  
{ object_t tmp(x); *this = move(tmp); return *this; }  
object_t& operator=(object_t&&) noexcept = default;  
  
friend void draw(const object_t& x, ostream& out, size_t position)  
{ x.self_>draw_(out, position); }  
  
private:  
struct concept_t {  
    virtual ~concept_t() = default;  
    virtual void draw_(ostream&, size_t) const = 0;  
};  
struct string_model_t final : concept_t {  
    string_model_t(string x) : data_(move(x)) { }  
    void draw_(ostream& out, size_t position) const override  
    { draw(data_, out, position); }  
  
    string data_;  
};
```



```
object_t(int x) : self_(make_unique<int_model_t>(move(x)))
{ }

object_t(const object_t& x) : self_(make_unique<int_model_t>(*x.self_))
{ }
object_t(object_t&&) noexcept = default;

object_t& operator=(const object_t& x)
{ object_t tmp(x); *this = move(tmp); return *this; }
object_t& operator=(object_t&&) noexcept = default;

friend void draw(const object_t& x, ostream& out, size_t position)
{ x.self_>draw_(out, position); }

private:
struct concept_t {
    virtual ~concept_t() = default;
    virtual void draw_(ostream&, size_t) const = 0;
};
struct string_model_t final : concept_t {
    string_model_t(string x) : data_(move(x)) { }
    void draw_(ostream& out, size_t position) const override
    { draw(data_, out, position); }

    string data_;
```

```
{ }
object_t(int x) : self_(make_unique<int_model_t>(move(x)))
{ }

object_t(const object_t& x) : self_(make_unique<int_model_t>(*x.self_))
{ }
object_t(object_t&&) noexcept = default;

object_t& operator=(const object_t& x)
{ object_t tmp(x); *this = move(tmp); return *this; }
object_t& operator=(object_t&&) noexcept = default;

friend void draw(const object_t& x, ostream& out, size_t position)
{ x.self_>draw_(out, position); }

private:
struct concept_t {
    virtual ~concept_t() = default;
    virtual void draw_(ostream&, size_t) const = 0;
};
struct string_model_t final : concept_t {
    string_model_t(string x) : data_(move(x)) { }
    void draw_(ostream& out, size_t position) const override
    { draw(data_, out, position); }
```

```
object_t(string x) : self_(make_unique<string_model_t>(move(x)))
{ }
object_t(int x) : self_(make_unique<int_model_t>(move(x)))
{ }

object_t(const object_t& x) : self_(make_unique<int_model_t>(*x.self_))
{ }
object_t(object_t&&) noexcept = default;

object_t& operator=(const object_t& x)
{ object_t tmp(x); *this = move(tmp); return *this; }
object_t& operator=(object_t&&) noexcept = default;

friend void draw(const object_t& x, ostream& out, size_t position)
{ x.self_>draw_(out, position); }

private:
struct concept_t {
    virtual ~concept_t() = default;
    virtual void draw_(ostream&, size_t) const = 0;
};
struct string_model_t final : concept_t {
    string_model_t(string x) : data_(move(x)) { }
    void draw_(ostream& out, size_t position) const override
    { draw(data_, out, position); }
```

client

library

```
public:
    object_t(string x) : self_(make_unique<string_model_t>(move(x)))
    { }
    object_t(int x) : self_(make_unique<int_model_t>(move(x)))
    { }

    object_t(const object_t& x) : self_(make_unique<int_model_t>(*x.self_))
    { }
    object_t(object_t&&) noexcept = default;

    object_t& operator=(const object_t& x)
    { object_t tmp(x); *this = move(tmp); return *this; }
    object_t& operator=(object_t&&) noexcept = default;

    friend void draw(const object_t& x, ostream& out, size_t position)
    { x.self_>draw_(out, position); }

private:
    struct concept_t {
        virtual ~concept_t() = default;
        virtual void draw_(ostream&, size_t) const = 0;
    };
    struct string_model_t final : concept_t {
        string_model_t(string x) : data_(move(x)) { }
        void draw_(ostream& out, size_t position) const override
```

cout

guidelines

defects

client

library

```
class object_t {
public:
    object_t(string x) : self_(make_unique<string_model_t>(move(x)))
    { }
    object_t(int x) : self_(make_unique<int_model_t>(move(x)))
    { }

    object_t(const object_t& x) : self_(make_unique<int_model_t>(*x.self_))
    { }
    object_t(object_t&&) noexcept = default;

    object_t& operator=(const object_t& x)
    { object_t tmp(x); *this = move(tmp); return *this; }
    object_t& operator=(object_t&&) noexcept = default;

    friend void draw(const object_t& x, ostream& out, size_t position)
    { x.self_>draw_(out, position); }

private:
    struct concept_t {
        virtual ~concept_t() = default;
        virtual void draw_(ostream&, size_t) const = 0;
    };
    struct string_model_t final : concept_t {
        string_model_t(string x) : data_(move(x)) { }

```

cout

guidelines

defects



```
class object_t {
public:
    object_t(string x) : self_(make_unique<string_model_t>(move(x)))
    { }
    object_t(int x) : self_(make_unique<int_model_t>(move(x)))
    { }

    object_t(const object_t& x) : self_(make_unique<int_model_t>(*x.self_))
    { }
    object_t(object_t&&) noexcept = default;

    object_t& operator=(const object_t& x)
    { object_t tmp(x); *this = move(tmp); return *this; }
    object_t& operator=(object_t&&) noexcept = default;

    friend void draw(const object_t& x, ostream& out, size_t position)
    { x.self_>draw_(out, position); }

private:
    struct concept_t {
        virtual ~concept_t() = default;
        virtual void draw_(ostream&, size_t) const = 0;
    };
    struct string_model_t final : concept_t {
```

client

library

```
{ out << string(position, ' ') << x << endl; }
```

```
class object_t {  
public:  
    object_t(string x) : self_(make_unique<string_model_t>(move(x)))  
    { }  
    object_t(int x) : self_(make_unique<int_model_t>(move(x)))  
    { }  
  
    object_t(const object_t& x) : self_(make_unique<int_model_t>(*x.self_))  
    { }  
    object_t(object_t&&) noexcept = default;  
  
    object_t& operator=(const object_t& x)  
    { object_t tmp(x); *this = move(tmp); return *this; }  
    object_t& operator=(object_t&&) noexcept = default;  
  
    friend void draw(const object_t& x, ostream& out, size_t position)  
    { x.self_>draw_(out, position); }  
  
private:  
    struct concept_t {  
        virtual ~concept_t() = default;  
        virtual void draw_(ostream&, size_t) const = 0;  
    };  
};
```



cout

guidelines

defects

client

library

```
void draw(const int& x, ostream& out, size_t position)
{ out << string(position, ' ') << x << endl; }

class object_t {
public:
    object_t(string x) : self_(make_unique<string_model_t>(move(x)))
    { }
    object_t(int x) : self_(make_unique<int_model_t>(move(x)))
    { }

    object_t(const object_t& x) : self_(make_unique<int_model_t>(*x.self_))
    { }
    object_t(object_t&&) noexcept = default;

    object_t& operator=(const object_t& x)
    { object_t tmp(x); *this = move(tmp); return *this; }
    object_t& operator=(object_t&&) noexcept = default;

    friend void draw(const object_t& x, ostream& out, size_t position)
    { x.self_>draw_(out, position); }

private:
    struct concept_t {
        virtual ~concept_t() = default;
        virtual void draw_(ostream&, size_t) const = 0;
    };
};
```

cout

guidelines

defects



```
void draw(const string& x, ostream& out, size_t position)
{ out << string(position, ' ') << x << endl; }
```

```
void draw(const int& x, ostream& out, size_t position)
{ out << string(position, ' ') << x << endl; }
```

```
class object_t {
public:
    object_t(string x) : self_(make_unique<string_model_t>(move(x)))
    { }
    object_t(int x) : self_(make_unique<int_model_t>(move(x)))
    { }

    object_t(const object_t& x) : self_(make_unique<int_model_t>(*x.self_))
    { }
    object_t(object_t&&) noexcept = default;

    object_t& operator=(const object_t& x)
    { object_t tmp(x); *this = move(tmp); return *this; }
    object_t& operator=(object_t&&) noexcept = default;

    friend void draw(const object_t& x, ostream& out, size_t position)
    { x.self_>draw_(out, position); }
```

private:



```
void draw(const string& x, ostream& out, size_t position)
{ out << string(position, ' ') << x << endl; }
```

```
void draw(const int& x, ostream& out, size_t position)
{ out << string(position, ' ') << x << endl; }
```

```
class object_t {
public:
    object_t(string x) : self_(make_unique<string_model_t>(move(x)))
    { }
    object_t(int x) : self_(make_unique<int_model_t>(move(x)))
    { }
```

```
object_t(const object_t& x) : self_(make_unique<int_model_t>(*x.self_))
{ }
```

```
object_t(object_t&&) noexcept = default;
```

```
object_t& operator=(const object_t& x)
{ object_t tmp(x); *this = move(tmp); return *this; }
object_t& operator=(object_t&&) noexcept = default;
```

```
friend void draw(const object_t& x, ostream& out, size_t position)
{ x.self_>draw_(out, position); }
```

```
private:
```



```
void draw(const string& x, ostream& out, size_t position)
{ out << string(position, ' ') << x << endl; }
```

```
void draw(const int& x, ostream& out, size_t position)
{ out << string(position, ' ') << x << endl; }
```

```
class object_t {
public:
    object_t(string x) : self_(make_unique<string_model_t>(move(x)))
    { }
    object_t(int x) : self_(make_unique<int_model_t>(move(x)))
    { }
```

```
object_t(const object_t& x) : self_(x.self_>copy_())
{ }
```

```
object_t(object_t&&) noexcept = default;
```

```
object_t& operator=(const object_t& x)
{ object_t tmp(x); *this = move(tmp); return *this; }
object_t& operator=(object_t&&) noexcept = default;
```

```
friend void draw(const object_t& x, ostream& out, size_t position)
{ x.self_>draw_(out, position); }
```

```
private:
```



```
void draw(const string& x, ostream& out, size_t position)
{ out << string(position, ' ') << x << endl; }
```

```
void draw(const int& x, ostream& out, size_t position)
{ out << string(position, ' ') << x << endl; }
```

```
class object_t {
public:
    object_t(string x) : self_(make_unique<string_model_t>(move(x)))
    { }
    object_t(int x) : self_(make_unique<int_model_t>(move(x)))
    { }

    object_t(const object_t& x) : self_(x.self_->copy_())
    { }
    object_t(object_t&&) noexcept = default;

    object_t& operator=(const object_t& x)
    { object_t tmp(x); *this = move(tmp); return *this; }
    object_t& operator=(object_t&&) noexcept = default;

    friend void draw(const object_t& x, ostream& out, size_t position)
    { x.self_->draw_(out, position); }
```

```
private:
```



client

library

```
{ out << string(position, ' ') << x << endl; }
```

```
void draw(const int& x, ostream& out, size_t position)
{ out << string(position, ' ') << x << endl; }
```

```
class object_t {
public:
    object_t(string x) : self_(make_unique<string_model_t>(move(x)))
    { }
    object_t(int x) : self_(make_unique<int_model_t>(move(x)))
    { }

    object_t(const object_t& x) : self_(x.self_>copy_())
    { }
    object_t(object_t&&) noexcept = default;

    object_t& operator=(const object_t& x)
    { object_t tmp(x); *this = move(tmp); return *this; }
    object_t& operator=(object_t&&) noexcept = default;

    friend void draw(const object_t& x, ostream& out, size_t position)
    { x.self_>draw_(out, position); }
```

```
private:
    struct concept_t {
```



cout

guidelines

defects

```
void draw(const int& x, ostream& out, size_t position)
{ out << string(position, ' ') << x << endl; }

class object_t {
public:
    object_t(string x) : self_(make_unique<string_model_t>(move(x)))
    { }
    object_t(int x) : self_(make_unique<int_model_t>(move(x)))
    { }

    object_t(const object_t& x) : self_(x.self_>copy_())
    { }
    object_t(object_t&&) noexcept = default;

    object_t& operator=(const object_t& x)
    { object_t tmp(x); *this = move(tmp); return *this; }
    object_t& operator=(object_t&&) noexcept = default;

    friend void draw(const object_t& x, ostream& out, size_t position)
    { x.self_>draw_(out, position); }

private:
    struct concept_t {
        virtual ~concept_t() = default;
    }
```

client

library

```
void draw(const int& x, ostream& out, size_t position)
{ out << string(position, ' ') << x << endl; }
```

```
class object_t {
public:
    object_t(string x) : self_(make_unique<string_model_t>(move(x)))
    { }
    object_t(int x) : self_(make_unique<int_model_t>(move(x)))
    { }

    object_t(const object_t& x) : self_(x.self_->copy_())
    { }
    object_t(object_t&&) noexcept = default;

    object_t& operator=(const object_t& x)
    { object_t tmp(x); *this = move(tmp); return *this; }
    object_t& operator=(object_t&&) noexcept = default;

    friend void draw(const object_t& x, ostream& out, size_t position)
    { x.self_->draw_(out, position); }

private:
    struct concept_t {
        virtual ~concept_t() = default;
        virtual void draw_(ostream&, size_t) const = 0;
    };
};
```

cout

guidelines

defects

client

library

```
{ out << string(position, ' ') << x << endl; }
```

```
class object_t {  
public:  
    object_t(string x) : self_(make_unique<string_model_t>(move(x)))  
    { }  
    object_t(int x) : self_(make_unique<int_model_t>(move(x)))  
    { }  
  
    object_t(const object_t& x) : self_(x.self_>copy_())  
    { }  
    object_t(object_t&&) noexcept = default;  
  
    object_t& operator=(const object_t& x)  
    { object_t tmp(x); *this = move(tmp); return *this; }  
    object_t& operator=(object_t&&) noexcept = default;  
  
    friend void draw(const object_t& x, ostream& out, size_t position)  
    { x.self_>draw_(out, position); }  
  
private:  
    struct concept_t {  
        virtual ~concept_t() = default;  
        virtual void draw_(ostream&, size_t) const = 0;  
    };  
};
```



cout

guidelines

defects



```
class object_t {
public:
    object_t(string x) : self_(make_unique<string_model_t>(move(x)))
    { }
    object_t(int x) : self_(make_unique<int_model_t>(move(x)))
    { }

    object_t(const object_t& x) : self_(x.self_->copy_())
    { }
    object_t(object_t&&) noexcept = default;

    object_t& operator=(const object_t& x)
    { object_t tmp(x); *this = move(tmp); return *this; }
    object_t& operator=(object_t&&) noexcept = default;

    friend void draw(const object_t& x, ostream& out, size_t position)
    { x.self_->draw_(out, position); }

private:
    struct concept_t {
        virtual ~concept_t() = default;
        virtual void draw_(ostream&, size_t) const = 0;
    };
    struct string_model_t final : concept_t {
```

client

library

```
class object_t {
public:
    object_t(string x) : self_(make_unique<string_model_t>(move(x)))
    { }
    object_t(int x) : self_(make_unique<int_model_t>(move(x)))
    { }

    object_t(const object_t& x) : self_(x.self_>copy_())
    { }
    object_t(object_t&&) noexcept = default;

    object_t& operator=(const object_t& x)
    { object_t tmp(x); *this = move(tmp); return *this; }
    object_t& operator=(object_t&&) noexcept = default;

    friend void draw(const object_t& x, ostream& out, size_t position)
    { x.self_>draw_(out, position); }

private:
    struct concept_t {
        virtual ~concept_t() = default;
        virtual void draw_(ostream&, size_t) const = 0;
    };
    struct string_model_t final : concept_t {
        string_model_t(string x) : data_(move(x)) { }
```

cout

guidelines

defects

client

library

```
public:
    object_t(string x) : self_(make_unique<string_model_t>(move(x)))
    { }
    object_t(int x) : self_(make_unique<int_model_t>(move(x)))
    { }

    object_t(const object_t& x) : self_(x.self_>copy_())
    { }
    object_t(object_t&&) noexcept = default;

    object_t& operator=(const object_t& x)
    { object_t tmp(x); *this = move(tmp); return *this; }
    object_t& operator=(object_t&&) noexcept = default;

    friend void draw(const object_t& x, ostream& out, size_t position)
    { x.self_>draw_(out, position); }

private:
    struct concept_t {
        virtual ~concept_t() = default;
        virtual void draw_(ostream&, size_t) const = 0;
    };
    struct string_model_t final : concept_t {
        string_model_t(string x) : data_(move(x)) { }
        void draw_(ostream& out, size_t position) const override
```

cout

guidelines

defects

```
object_t(string x) : self_(make_unique<string_model_t>(move(x)))
{ }
object_t(int x) : self_(make_unique<int_model_t>(move(x)))
{ }

object_t(const object_t& x) : self_(x.self_>copy_())
{ }
object_t(object_t&&) noexcept = default;

object_t& operator=(const object_t& x)
{ object_t tmp(x); *this = move(tmp); return *this; }
object_t& operator=(object_t&&) noexcept = default;

friend void draw(const object_t& x, ostream& out, size_t position)
{ x.self_>draw_(out, position); }

private:
struct concept_t {
    virtual ~concept_t() = default;
    virtual void draw_(ostream&, size_t) const = 0;
};
struct string_model_t final : concept_t {
    string_model_t(string x) : data_(move(x)) { }
    void draw_(ostream& out, size_t position) const override
    { draw(data_, out, position); }
```

```
{ }
object_t(int x) : self_(make_unique<int_model_t>(move(x)))
{ }

object_t(const object_t& x) : self_(x.self_>copy_())
{ }
object_t(object_t&&) noexcept = default;

object_t& operator=(const object_t& x)
{ object_t tmp(x); *this = move(tmp); return *this; }
object_t& operator=(object_t&&) noexcept = default;

friend void draw(const object_t& x, ostream& out, size_t position)
{ x.self_>draw_(out, position); }

private:
struct concept_t {
    virtual ~concept_t() = default;
    virtual void draw_(ostream&, size_t) const = 0;
};
struct string_model_t final : concept_t {
    string_model_t(string x) : data_(move(x)) { }
    void draw_(ostream& out, size_t position) const override
    { draw(data_, out, position); }
```



```
object_t(int x) : self_(make_unique<int_model_t>(move(x)))
{ }

object_t(const object_t& x) : self_(x.self_>copy_())
{ }
object_t(object_t&&) noexcept = default;

object_t& operator=(const object_t& x)
{ object_t tmp(x); *this = move(tmp); return *this; }
object_t& operator=(object_t&&) noexcept = default;

friend void draw(const object_t& x, ostream& out, size_t position)
{ x.self_>draw_(out, position); }

private:
struct concept_t {
    virtual ~concept_t() = default;
    virtual void draw_(ostream&, size_t) const = 0;
};
struct string_model_t final : concept_t {
    string_model_t(string x) : data_(move(x)) { }
    void draw_(ostream& out, size_t position) const override
    { draw(data_, out, position); }

    string data_;
```



```
{ }

object_t(const object_t& x) : self_(x.self_>copy_())
{ }
object_t(object_t&&) noexcept = default;

object_t& operator=(const object_t& x)
{ object_t tmp(x); *this = move(tmp); return *this; }
object_t& operator=(object_t&&) noexcept = default;

friend void draw(const object_t& x, ostream& out, size_t position)
{ x.self_>draw_(out, position); }

private:
struct concept_t {
    virtual ~concept_t() = default;
    virtual void draw_(ostream&, size_t) const = 0;
};
struct string_model_t final : concept_t {
    string_model_t(string x) : data_(move(x)) { }
    void draw_(ostream& out, size_t position) const override
    { draw(data_, out, position); }

    string data_;
};
```



```
object_t(const object_t& x) : self_(x.self_>copy_())
{ }
object_t(object_t&&) noexcept = default;

object_t& operator=(const object_t& x)
{ object_t tmp(x); *this = move(tmp); return *this; }
object_t& operator=(object_t&&) noexcept = default;

friend void draw(const object_t& x, ostream& out, size_t position)
{ x.self_>draw_(out, position); }

private:
struct concept_t {
    virtual ~concept_t() = default;
    virtual void draw_(ostream&, size_t) const = 0;
};
struct string_model_t final : concept_t {
    string_model_t(string x) : data_(move(x)) { }
    void draw_(ostream& out, size_t position) const override
    { draw(data_, out, position); }

    string data_;
};
struct int_model_t final : concept_t {
```



```
object_t(const object_t& x) : self_(x.self_>copy_())
{ }
object_t(object_t&&) noexcept = default;

object_t& operator=(const object_t& x)
{ object_t tmp(x); *this = move(tmp); return *this; }
object_t& operator=(object_t&&) noexcept = default;

friend void draw(const object_t& x, ostream& out, size_t position)
{ x.self_>draw_(out, position); }

private:
struct concept_t {
    virtual ~concept_t() = default;
    virtual void draw_(ostream&, size_t) const = 0;
};
struct string_model_t final : concept_t {
    string_model_t(string x) : data_(move(x)) { }
    void draw_(ostream& out, size_t position) const override
    { draw(data_, out, position); }

    string data_;
};
struct int_model_t final : concept_t {
    int_model_t(int x) : data_(move(x)) { }
```

client

library

```
{ }
object_t(object_t&&) noexcept = default;

object_t& operator=(const object_t& x)
{ object_t tmp(x); *this = move(tmp); return *this; }
object_t& operator=(object_t&&) noexcept = default;

friend void draw(const object_t& x, ostream& out, size_t position)
{ x.self_->draw_(out, position); }

private:
struct concept_t {
    virtual ~concept_t() = default;
    virtual void draw_(ostream&, size_t) const = 0;
};
struct string_model_t final : concept_t {
    string_model_t(string x) : data_(move(x)) { }
    void draw_(ostream& out, size_t position) const override
    { draw(data_, out, position); }

    string data_;
};
struct int_model_t final : concept_t {
    int_model_t(int x) : data_(move(x)) { }
    void draw_(ostream& out, size_t position) const override
```

cout

guidelines

defects

client

library

```
object_t(object_t&&) noexcept = default;

object_t& operator=(const object_t& x)
{ object_t tmp(x); *this = move(tmp); return *this; }
object_t& operator=(object_t&&) noexcept = default;

friend void draw(const object_t& x, ostream& out, size_t position)
{ x.self_>draw_(out, position); }

private:
struct concept_t {
    virtual ~concept_t() = default;
    virtual void draw_(ostream&, size_t) const = 0;
};
struct string_model_t final : concept_t {
    string_model_t(string x) : data_(move(x)) { }
    void draw_(ostream& out, size_t position) const override
    { draw(data_, out, position); }

    string data_;
};
struct int_model_t final : concept_t {
    int_model_t(int x) : data_(move(x)) { }
    void draw_(ostream& out, size_t position) const override
    { draw(data_, out, position); }
}
```

cout

guidelines

defects

```
object_t& operator=(const object_t& x)
{ object_t tmp(x); *this = move(tmp); return *this; }
object_t& operator=(object_t&&) noexcept = default;

friend void draw(const object_t& x, ostream& out, size_t position)
{ x.self_->draw_(out, position); }

private:
struct concept_t {
    virtual ~concept_t() = default;
    virtual void draw_(ostream&, size_t) const = 0;
};
struct string_model_t final : concept_t {
    string_model_t(string x) : data_(move(x)) { }
    void draw_(ostream& out, size_t position) const override
    { draw(data_, out, position); }

    string data_;
};
struct int_model_t final : concept_t {
    int_model_t(int x) : data_(move(x)) { }
    void draw_(ostream& out, size_t position) const override
    { draw(data_, out, position); }
```



```
object_t& operator=(const object_t& x)
{ object_t tmp(x); *this = move(tmp); return *this; }
object_t& operator=(object_t&&) noexcept = default;

friend void draw(const object_t& x, ostream& out, size_t position)
{ x.self_->draw_(out, position); }
```

private:

```
struct concept_t {
    virtual ~concept_t() = default;
    virtual void draw_(ostream&, size_t) const = 0;
};

struct string_model_t final : concept_t {
    string_model_t(string x) : data_(move(x)) { }
    void draw_(ostream& out, size_t position) const override
    { draw(data_, out, position); }

    string data_;
};

struct int_model_t final : concept_t {
    int_model_t(int x) : data_(move(x)) { }
    void draw_(ostream& out, size_t position) const override
    { draw(data_, out, position); }

    int data_;
```



client

library

```
{ object_t tmp(x); *this = move(tmp); return *this; }
object_t& operator=(object_t&&) noexcept = default;

friend void draw(const object_t& x, ostream& out, size_t position)
{ x.self_->draw_(out, position); }
```

private:

```
struct concept_t {
    virtual ~concept_t() = default;
    virtual void draw_(ostream&, size_t) const = 0;
};
struct string_model_t final : concept_t {
    string_model_t(string x) : data_(move(x)) { }
    void draw_(ostream& out, size_t position) const override
    { draw(data_, out, position); }

    string data_;
};
struct int_model_t final : concept_t {
    int_model_t(int x) : data_(move(x)) { }
    void draw_(ostream& out, size_t position) const override
    { draw(data_, out, position); }

    int data_;
};
```



cout

guidelines

defects

```
object_t& operator=(object_t&&) noexcept = default;

friend void draw(const object_t& x, ostream& out, size_t position)
{ x.self_>draw_(out, position); }

private:
struct concept_t {
    virtual ~concept_t() = default;
    virtual void draw_(ostream&, size_t) const = 0;
};
struct string_model_t final : concept_t {
    string_model_t(string x) : data_(move(x)) { }
    void draw_(ostream& out, size_t position) const override
    { draw(data_, out, position); }

    string data_;
};
struct int_model_t final : concept_t {
    int_model_t(int x) : data_(move(x)) { }
    void draw_(ostream& out, size_t position) const override
    { draw(data_, out, position); }

    int data_;
};
```



```
friend void draw(const object_t& x, ostream& out, size_t position)
{ x.self_>draw_(out, position); }
```

private:

```
struct concept_t {
    virtual ~concept_t() = default;
    virtual void draw_(ostream&, size_t) const = 0;
};
struct string_model_t final : concept_t {
    string_model_t(string x) : data_(move(x)) { }
    void draw_(ostream& out, size_t position) const override
    { draw(data_, out, position); }

    string data_;
};
struct int_model_t final : concept_t {
    int_model_t(int x) : data_(move(x)) { }
    void draw_(ostream& out, size_t position) const override
    { draw(data_, out, position); }

    int data_;
};
```

```
unique_ptr<concept_t> self_;
```





```
friend void draw(const object_t& x, ostream& out, size_t position)
{ x.self_>draw_(out, position); }

private:
struct concept_t {
    virtual ~concept_t() = default;
    virtual void draw_(ostream&, size_t) const = 0;
};
struct string_model_t final : concept_t {
    string_model_t(string x) : data_(move(x)) { }
    void draw_(ostream& out, size_t position) const override
    { draw(data_, out, position); }

    string data_;
};
struct int_model_t final : concept_t {
    int_model_t(int x) : data_(move(x)) { }
    void draw_(ostream& out, size_t position) const override
    { draw(data_, out, position); }

    int data_;
};

unique_ptr<concept_t> self_;
};
```

```
friend void draw(const object_t& x, ostream& out, size_t position)
{ x.self_>draw_(out, position); }
```

private:

```
struct concept_t {
    virtual ~concept_t() = default;
    virtual unique_ptr<concept_t> copy_() const = 0;
    virtual void draw_(ostream&, size_t) const = 0;
};
struct string_model_t final : concept_t {
    string_model_t(string x) : data_(move(x)) { }
    unique_ptr<concept_t> copy_() const override
    { return make_unique<string_model_t>(*this); }
    void draw_(ostream& out, size_t position) const override
    { draw(data_, out, position); }

    string data_;
};
struct int_model_t final : concept_t {
    int_model_t(int x) : data_(move(x)) { }
    unique_ptr<concept_t> copy_() const override
    { return make_unique<int_model_t>(*this); }
    void draw_(ostream& out, size_t position) const override
    { draw(data_, out, position); }
```

client

library

```
int main()
{
    document_t document;

    document.emplace_back(0);
    document.emplace_back(1);
    document.emplace_back(2);
    document.emplace_back(3);

    draw(document, cout, 0);
}
```

cout

guidelines

defects

client

library

```
int main()
{
    document_t document;

    document.emplace_back(0);
    document.emplace_back(string("Hello!"));
    document.emplace_back(2);
    document.emplace_back(3);

    draw(document, cout, 0);
}
```

cout

guidelines

defects

```
void draw(const string& x, ostream& out, size_t position)
{ out << string(position, ' ') << x << endl; }
```

```
void draw(const int& x, ostream& out, size_t position)
{ out << string(position, ' ') << x << endl; }
```

```
class object_t {
public:
```

```
    object_t(string x) : self_(make_unique<string_model_t>(move(x)))
    { }
    object_t(int x) : self_(make_unique<int_model_t>(move(x)))
    { }
```

```
    object_t(const object_t& x) : self_(x.self_->copy_())
    { }
    object_t(object_t&&) noexcept = default;
```

```
    object_t& operator=(const object_t& x)
    { object_t tmp(x); *this = move(tmp); return *this; }
    object_t& operator=(object_t&&) noexcept = default;
```

```
    friend void draw(const object_t& x, ostream& out, size_t position)
    { x.self_->draw_(out, position); }
```

```
private:
```



```
template <typename T>
void draw(const T& x, ostream& out, size_t position)
{ out << string(position, ' ') << x << endl; }
```

```
class object_t {
public:
```

```
    template <typename T>
    object_t(T x) : self_(make_unique<model<T>>(move(x)))
    { }
```

```
    object_t(const object_t& x) : self_(x.self_>copy_())
    { }
```

```
    object_t(object_t&&) noexcept = default;
```

```
    object_t& operator=(const object_t& x)
    { object_t tmp(x); *this = move(tmp); return *this; }
    object_t& operator=(object_t&&) noexcept = default;
```

```
    friend void draw(const object_t& x, ostream& out, size_t position)
    { x.self_>draw_(out, position); }
```

```
private:
```

```
    struct concept_t {
        virtual ~concept_t() = default;
        virtual unique_ptr<concept_t> copy_() const = 0;
```

```
template <typename T>
void draw(const T& x, ostream& out, size_t position)
{ out << string(position, ' ') << x << endl; }

class object_t {
public:
    template <typename T>
    object_t(T x) : self_(make_unique<model<T>>(move(x)))
    { }

    object_t(const object_t& x) : self_(x.self_->copy_())
    { }
    object_t(object_t&&) noexcept = default;

    object_t& operator=(const object_t& x)
    { object_t tmp(x); *this = move(tmp); return *this; }
    object_t& operator=(object_t&&) noexcept = default;

    friend void draw(const object_t& x, ostream& out, size_t position)
    { x.self_->draw_(out, position); }

private:
    struct concept_t {
        virtual ~concept_t() = default;
        virtual unique_ptr<concept_t> copy_() const = 0;
    };
};
```

client

library

```
void draw(const T& x, ostream& out, size_t position)
{ out << string(position, ' ') << x << endl; }
```

```
class object_t {
public:
    template <typename T>
    object_t(T x) : self_(make_unique<model<T>>(move(x)))
    { }

    object_t(const object_t& x) : self_(x.self_->copy_())
    { }
    object_t(object_t&&) noexcept = default;

    object_t& operator=(const object_t& x)
    { object_t tmp(x); *this = move(tmp); return *this; }
    object_t& operator=(object_t&&) noexcept = default;

    friend void draw(const object_t& x, ostream& out, size_t position)
    { x.self_->draw_(out, position); }

private:
    struct concept_t {
        virtual ~concept_t() = default;
        virtual unique_ptr<concept_t> copy_() const = 0;
        virtual void draw_(ostream&, size_t) const = 0;
    };
};
```

cout

guidelines

defects



client

library

```
{ out << string(position, ' ') << x << endl; }
```

```
class object_t {  
public:  
    template <typename T>  
    object_t(T x) : self_(make_unique<model<T>>(move(x)))  
    { }  
  
    object_t(const object_t& x) : self_(x.self_->copy_())  
    { }  
    object_t(object_t&&) noexcept = default;  
  
    object_t& operator=(const object_t& x)  
    { object_t tmp(x); *this = move(tmp); return *this; }  
    object_t& operator=(object_t&&) noexcept = default;  
  
    friend void draw(const object_t& x, ostream& out, size_t position)  
    { x.self_->draw_(out, position); }  
  
private:  
    struct concept_t {  
        virtual ~concept_t() = default;  
        virtual unique_ptr<concept_t> copy_() const = 0;  
        virtual void draw_(ostream&, size_t) const = 0;  
    };
```

cout

guidelines

defects

client

library



```
class object_t {
public:
    template <typename T>
    object_t(T x) : self_(make_unique<model<T>>(move(x)))
    { }

    object_t(const object_t& x) : self_(x.self_>copy_())
    { }
    object_t(object_t&&) noexcept = default;

    object_t& operator=(const object_t& x)
    { object_t tmp(x); *this = move(tmp); return *this; }
    object_t& operator=(object_t&&) noexcept = default;

    friend void draw(const object_t& x, ostream& out, size_t position)
    { x.self_>draw_(out, position); }

private:
    struct concept_t {
        virtual ~concept_t() = default;
        virtual unique_ptr<concept_t> copy_() const = 0;
        virtual void draw_(ostream&, size_t) const = 0;
    };
    struct string_model_t final : concept_t {
```

cout

guidelines

defects

client

library

```
class object_t {
public:
    template <typename T>
    object_t(T x) : self_(make_unique<model<T>>(move(x)))
    { }

    object_t(const object_t& x) : self_(x.self_>copy_())
    { }
    object_t(object_t&&) noexcept = default;

    object_t& operator=(const object_t& x)
    { object_t tmp(x); *this = move(tmp); return *this; }
    object_t& operator=(object_t&&) noexcept = default;

    friend void draw(const object_t& x, ostream& out, size_t position)
    { x.self_>draw_(out, position); }

private:
    struct concept_t {
        virtual ~concept_t() = default;
        virtual unique_ptr<concept_t> copy_() const = 0;
        virtual void draw_(ostream&, size_t) const = 0;
    };
    struct string_model_t final : concept_t {
        string_model_t(string x) : data_(move(x)) { }
```

cout

guidelines

defects

client

library

```
public:
    template <typename T>
    object_t(T x) : self_(make_unique<model<T>>(move(x)))
    { }

    object_t(const object_t& x) : self_(x.self_->copy_())
    { }
    object_t(object_t&&) noexcept = default;

    object_t& operator=(const object_t& x)
    { object_t tmp(x); *this = move(tmp); return *this; }
    object_t& operator=(object_t&&) noexcept = default;

    friend void draw(const object_t& x, ostream& out, size_t position)
    { x.self_->draw_(out, position); }

private:
    struct concept_t {
        virtual ~concept_t() = default;
        virtual unique_ptr<concept_t> copy_() const = 0;
        virtual void draw_(ostream&, size_t) const = 0;
    };
    struct string_model_t final : concept_t {
        string_model_t(string x) : data_(move(x)) { }
        unique_ptr<concept_t> copy_() const override
```

cout

guidelines

defects

client

library

```
template <typename T>
object_t(T x) : self_(make_unique<model<T>>(move(x)))
{ }

object_t(const object_t& x) : self_(x.self_>copy_())
{ }
object_t(object_t&&) noexcept = default;

object_t& operator=(const object_t& x)
{ object_t tmp(x); *this = move(tmp); return *this; }
object_t& operator=(object_t&&) noexcept = default;

friend void draw(const object_t& x, ostream& out, size_t position)
{ x.self_>draw_(out, position); }

private:
struct concept_t {
    virtual ~concept_t() = default;
    virtual unique_ptr<concept_t> copy_() const = 0;
    virtual void draw_(ostream&, size_t) const = 0;
};
struct string_model_t final : concept_t {
    string_model_t(string x) : data_(move(x)) { }
    unique_ptr<concept_t> copy_() const override
    { return make_unique<string_model_t>(*this); }
```

cout

guidelines

defects

client

library

```
object_t(T x) : self_(make_unique<model<T>>(move(x)))
{ }

object_t(const object_t& x) : self_(x.self_->copy_())
{ }
object_t(object_t&&) noexcept = default;

object_t& operator=(const object_t& x)
{ object_t tmp(x); *this = move(tmp); return *this; }
object_t& operator=(object_t&&) noexcept = default;

friend void draw(const object_t& x, ostream& out, size_t position)
{ x.self_->draw_(out, position); }

private:
struct concept_t {
    virtual ~concept_t() = default;
    virtual unique_ptr<concept_t> copy_() const = 0;
    virtual void draw_(ostream&, size_t) const = 0;
};
struct string_model_t final : concept_t {
    string_model_t(string x) : data_(move(x)) { }
    unique_ptr<concept_t> copy_() const override
    { return make_unique<string_model_t>(*this); }
    void draw_(ostream& out, size_t position) const override
```

cout

guidelines

defects

client

library

```
{ }  
  
object_t(const object_t& x) : self_(x.self_>copy_())  
{ }  
object_t(object_t&&) noexcept = default;  
  
object_t& operator=(const object_t& x)  
{ object_t tmp(x); *this = move(tmp); return *this; }  
object_t& operator=(object_t&&) noexcept = default;  
  
friend void draw(const object_t& x, ostream& out, size_t position)  
{ x.self_>draw_(out, position); }  
  
private:  
struct concept_t {  
    virtual ~concept_t() = default;  
    virtual unique_ptr<concept_t> copy_() const = 0;  
    virtual void draw_(ostream&, size_t) const = 0;  
};  
struct string_model_t final : concept_t {  
    string_model_t(string x) : data_(move(x)) { }  
    unique_ptr<concept_t> copy_() const override  
    { return make_unique<string_model_t>(*this); }  
    void draw_(ostream& out, size_t position) const override  
    { draw(data_, out, position); }  
};
```

cout

guidelines

defects

client

library



```
object_t(const object_t& x) : self_(x.self_>copy_())
{ }
object_t(object_t&&) noexcept = default;

object_t& operator=(const object_t& x)
{ object_t tmp(x); *this = move(tmp); return *this; }
object_t& operator=(object_t&&) noexcept = default;

friend void draw(const object_t& x, ostream& out, size_t position)
{ x.self_>draw_(out, position); }

private:
struct concept_t {
    virtual ~concept_t() = default;
    virtual unique_ptr<concept_t> copy_() const = 0;
    virtual void draw_(ostream&, size_t) const = 0;
};
struct string_model_t final : concept_t {
    string_model_t(string x) : data_(move(x)) { }
    unique_ptr<concept_t> copy_() const override
    { return make_unique<string_model_t>(*this); }
    void draw_(ostream& out, size_t position) const override
    { draw(data_, out, position); }
```



cout

guidelines

defects



client

library

```
object_t(const object_t& x) : self_(x.self_>copy_())  
{ }  
object_t(object_t&&) noexcept = default;  
  
object_t& operator=(const object_t& x)  
{ object_t tmp(x); *this = move(tmp); return *this; }  
object_t& operator=(object_t&&) noexcept = default;  
  
friend void draw(const object_t& x, ostream& out, size_t position)  
{ x.self_>draw_(out, position); }
```

private:

```
struct concept_t {  
    virtual ~concept_t() = default;  
    virtual unique_ptr<concept_t> copy_() const = 0;  
    virtual void draw_(ostream&, size_t) const = 0;  
};  
struct string_model_t final : concept_t {  
    string_model_t(string x) : data_(move(x)) { }  
    unique_ptr<concept_t> copy_() const override  
    { return make_unique<string_model_t>(*this); }  
    void draw_(ostream& out, size_t position) const override  
    { draw(data_, out, position); }  
  
    string data_;
```

cout

guidelines

defects

client

library

```
{ }  
object_t(object_t&&) noexcept = default;  
  
object_t& operator=(const object_t& x)  
{ object_t tmp(x); *this = move(tmp); return *this; }  
object_t& operator=(object_t&&) noexcept = default;  
  
friend void draw(const object_t& x, ostream& out, size_t position)  
{ x.self_->draw_(out, position); }  
  
private:  
struct concept_t {  
    virtual ~concept_t() = default;  
    virtual unique_ptr<concept_t> copy_() const = 0;  
    virtual void draw_(ostream&, size_t) const = 0;  
};  
struct string_model_t final : concept_t {  
    string_model_t(string x) : data_(move(x)) { }  
    unique_ptr<concept_t> copy_() const override  
    { return make_unique<string_model_t>(*this); }  
    void draw_(ostream& out, size_t position) const override  
    { draw(data_, out, position); }  
  
    string data_;  
};
```

cout

guidelines

defects

client

library

```
object_t(object_t&&) noexcept = default;
```

```
object_t& operator=(const object_t& x)  
{ object_t tmp(x); *this = move(tmp); return *this; }  
object_t& operator=(object_t&&) noexcept = default;
```

```
friend void draw(const object_t& x, ostream& out, size_t position)  
{ x.self_>draw_(out, position); }
```

private:

```
struct concept_t {  
    virtual ~concept_t() = default;  
    virtual unique_ptr<concept_t> copy_() const = 0;  
    virtual void draw_(ostream&, size_t) const = 0;  
};  
struct string_model_t final : concept_t {  
    string_model_t(string x) : data_(move(x)) { }  
    unique_ptr<concept_t> copy_() const override  
    { return make_unique<string_model_t>(*this); }  
    void draw_(ostream& out, size_t position) const override  
    { draw(data_, out, position); }  
  
    string data_;  
};  
struct int_model_t final : concept_t {
```

cout

guidelines

defects



```
object_t& operator=(const object_t& x)
{ object_t tmp(x); *this = move(tmp); return *this; }
object_t& operator=(object_t&&) noexcept = default;

friend void draw(const object_t& x, ostream& out, size_t position)
{ x.self_>draw_(out, position); }
```

private:

```
struct concept_t {
    virtual ~concept_t() = default;
    virtual unique_ptr<concept_t> copy_() const = 0;
    virtual void draw_(ostream&, size_t) const = 0;
};

struct string_model_t final : concept_t {
    string_model_t(string x) : data_(move(x)) { }
    unique_ptr<concept_t> copy_() const override
    { return make_unique<string_model_t>(*this); }
    void draw_(ostream& out, size_t position) const override
    { draw(data_, out, position); }

    string data_;
};

struct int_model_t final : concept_t {
    int_model_t(int x) : data_(move(x)) { }
```



client

library

```
object_t& operator=(const object_t& x)
{ object_t tmp(x); *this = move(tmp); return *this; }
object_t& operator=(object_t&&) noexcept = default;

friend void draw(const object_t& x, ostream& out, size_t position)
{ x.self_->draw_(out, position); }
```

private:

```
struct concept_t {
    virtual ~concept_t() = default;
    virtual unique_ptr<concept_t> copy_() const = 0;
    virtual void draw_(ostream&, size_t) const = 0;
};

struct string_model_t final : concept_t {
    string_model_t(string x) : data_(move(x)) { }
    unique_ptr<concept_t> copy_() const override
    { return make_unique<string_model_t>(*this); }
    void draw_(ostream& out, size_t position) const override
    { draw(data_, out, position); }

    string data_;
};

struct int_model_t final : concept_t {
    int_model_t(int x) : data_(move(x)) { }
    unique_ptr<concept_t> copy_() const override
```

cout

guidelines

defects

client

library

```
{ object_t tmp(x); *this = move(tmp); return *this; }
object_t& operator=(object_t&&) noexcept = default;

friend void draw(const object_t& x, ostream& out, size_t position)
{ x.self_->draw_(out, position); }
```

private:

```
struct concept_t {
    virtual ~concept_t() = default;
    virtual unique_ptr<concept_t> copy_() const = 0;
    virtual void draw_(ostream&, size_t) const = 0;
};

struct string_model_t final : concept_t {
    string_model_t(string x) : data_(move(x)) { }
    unique_ptr<concept_t> copy_() const override
    { return make_unique<string_model_t>(*this); }
    void draw_(ostream& out, size_t position) const override
    { draw(data_, out, position); }

    string data_;
};

struct int_model_t final : concept_t {
    int_model_t(int x) : data_(move(x)) { }
    unique_ptr<concept_t> copy_() const override
    { return make_unique<int_model_t>(*this); }
```

cout

guidelines

defects

client

library

```
object_t& operator=(object_t&&) noexcept = default;

friend void draw(const object_t& x, ostream& out, size_t position)
{ x.self_->draw_(out, position); }

private:
struct concept_t {
    virtual ~concept_t() = default;
    virtual unique_ptr<concept_t> copy_() const = 0;
    virtual void draw_(ostream&, size_t) const = 0;
};
struct string_model_t final : concept_t {
    string_model_t(string x) : data_(move(x)) { }
    unique_ptr<concept_t> copy_() const override
    { return make_unique<string_model_t>(*this); }
    void draw_(ostream& out, size_t position) const override
    { draw(data_, out, position); }

    string data_;
};
struct int_model_t final : concept_t {
    int_model_t(int x) : data_(move(x)) { }
    unique_ptr<concept_t> copy_() const override
    { return make_unique<int_model_t>(*this); }
    void draw_(ostream& out, size_t position) const override
```

cout

guidelines

defects

client

library



```
friend void draw(const object_t& x, ostream& out, size_t position)
{ x.self_->draw_(out, position); }
```

private:

```
struct concept_t {
    virtual ~concept_t() = default;
    virtual unique_ptr<concept_t> copy_() const = 0;
    virtual void draw_(ostream&, size_t) const = 0;
};
struct string_model_t final : concept_t {
    string_model_t(string x) : data_(move(x)) { }
    unique_ptr<concept_t> copy_() const override
    { return make_unique<string_model_t>(*this); }
    void draw_(ostream& out, size_t position) const override
    { draw(data_, out, position); }

    string data_;
};
struct int_model_t final : concept_t {
    int_model_t(int x) : data_(move(x)) { }
    unique_ptr<concept_t> copy_() const override
    { return make_unique<int_model_t>(*this); }
    void draw_(ostream& out, size_t position) const override
    { draw(data_, out, position); }
```



cout

guidelines

defects



client

library

```
friend void draw(const object_t& x, ostream& out, size_t position)
{ x.self_>draw_(out, position); }
```

private:

```
struct concept_t {
    virtual ~concept_t() = default;
    virtual unique_ptr<concept_t> copy_() const = 0;
    virtual void draw_(ostream&, size_t) const = 0;
};
struct string_model_t final : concept_t {
    string_model_t(string x) : data_(move(x)) { }
    unique_ptr<concept_t> copy_() const override
    { return make_unique<string_model_t>(*this); }
    void draw_(ostream& out, size_t position) const override
    { draw(data_, out, position); }

    string data_;
};
struct int_model_t final : concept_t {
    int_model_t(int x) : data_(move(x)) { }
    unique_ptr<concept_t> copy_() const override
    { return make_unique<int_model_t>(*this); }
    void draw_(ostream& out, size_t position) const override
    { draw(data_, out, position); }
```

cout

guidelines

defects

client

library

```
{ x.self_>draw_(out, position); }
```

private:

```
struct concept_t {  
    virtual ~concept_t() = default;  
    virtual unique_ptr<concept_t> copy_() const = 0;  
    virtual void draw_(ostream&, size_t) const = 0;  
};  
struct string_model_t final : concept_t {  
    string_model_t(string x) : data_(move(x)) { }  
    unique_ptr<concept_t> copy_() const override  
    { return make_unique<string_model_t>(*this); }  
    void draw_(ostream& out, size_t position) const override  
    { draw(data_, out, position); }  
  
    string data_;  
};  
struct int_model_t final : concept_t {  
    int_model_t(int x) : data_(move(x)) { }  
    unique_ptr<concept_t> copy_() const override  
    { return make_unique<int_model_t>(*this); }  
    void draw_(ostream& out, size_t position) const override  
    { draw(data_, out, position); }  
  
    int data_;
```

cout

guidelines

defects

client

library



```
private:
    struct concept_t {
        virtual ~concept_t() = default;
        virtual unique_ptr<concept_t> copy_() const = 0;
        virtual void draw_(ostream&, size_t) const = 0;
    };
    struct string_model_t final : concept_t {
        string_model_t(string x) : data_(move(x)) { }
        unique_ptr<concept_t> copy_() const override
        { return make_unique<string_model_t>(*this); }
        void draw_(ostream& out, size_t position) const override
        { draw(data_, out, position); }

        string data_;
    };
    struct int_model_t final : concept_t {
        int_model_t(int x) : data_(move(x)) { }
        unique_ptr<concept_t> copy_() const override
        { return make_unique<int_model_t>(*this); }
        void draw_(ostream& out, size_t position) const override
        { draw(data_, out, position); }

        int data_;
    };
```



cout

guidelines

defects

```
private:
    struct concept_t {
        virtual ~concept_t() = default;
        virtual unique_ptr<concept_t> copy_() const = 0;
        virtual void draw_(ostream&, size_t) const = 0;
    };
    struct string_model_t final : concept_t {
        string_model_t(string x) : data_(move(x)) { }
        unique_ptr<concept_t> copy_() const override
        { return make_unique<string_model_t>(*this); }
        void draw_(ostream& out, size_t position) const override
        { draw(data_, out, position); }

        string data_;
    };
    struct int_model_t final : concept_t {
        int_model_t(int x) : data_(move(x)) { }
        unique_ptr<concept_t> copy_() const override
        { return make_unique<int_model_t>(*this); }
        void draw_(ostream& out, size_t position) const override
        { draw(data_, out, position); }

        int data_;
    };
```

private:

```
struct concept_t {  
    virtual ~concept_t() = default;  
    virtual unique_ptr<concept_t> copy_() const = 0;  
    virtual void draw_(ostream&, size_t) const = 0;  
};
```

```
struct string_model_t final : concept_t {  
    string_model_t(string x) : data_(move(x)) { }  
    unique_ptr<concept_t> copy_() const override  
    { return make_unique<string_model_t>(*this); }  
    void draw_(ostream& out, size_t position) const override  
    { draw(data_, out, position); }
```

```
    string data_;
```

```
};
```

```
struct int_model_t final : concept_t {  
    int_model_t(int x) : data_(move(x)) { }  
    unique_ptr<concept_t> copy_() const override  
    { return make_unique<int_model_t>(*this); }  
    void draw_(ostream& out, size_t position) const override  
    { draw(data_, out, position); }
```

```
    int data_;
```

```
};
```

```
private:
    struct concept_t {
        virtual ~concept_t() = default;
        virtual unique_ptr<concept_t> copy_() const = 0;
        virtual void draw_(ostream&, size_t) const = 0;
    };
```

```
template <typename T>
struct model final : concept_t {
    model(T x) : data_(move(x)) { }
    unique_ptr<concept_t> copy_() const override
    { return make_unique<model>(*this); }
    void draw_(ostream& out, size_t position) const override
    { draw(data_, out, position); }

    T data_;
};
```

```
    unique_ptr<concept_t> self_;
};
```

```
using document_t = vector<object_t>;
```

```
void draw(const document_t& x, ostream& out, size_t position)
{
    out << string(position, ' ') << "<document>" << endl;
```

```
class my_class_t {  
    /* ... */  
};  
  
void draw(const my_class_t&, ostream& out, size_t position)  
{ out << string(position, ' ') << "my_class_t" << endl; }
```

```
int main()  
{  
    document_t document;  
  
    document.emplace_back(0);  
    document.emplace_back(string("Hello!"));  
    document.emplace_back(2);  
    document.emplace_back(my_class_t());  
  
    draw(document, cout, 0);  
}
```

```
class my_class_t {  
    /* ... */  
};  
  
void draw(const my_class_t&, ostream& out, size_t position)  
{ out << string(position, ' ') << "my_class_t" << endl; }  
  
int main()  
{  
    document_t document;  
  
    document.emplace_back(0);  
    document.emplace_back(string("Hello!"));  
    document.emplace_back(document);  
    document.emplace_back(my_class_t());  
  
    draw(document, cout, 0);  
}
```



# Polymorphic Use

- Shifting polymorphism from *type* to *use* allows for greater reuse and fewer dependencies
- Using regular semantics for the common basis operations, copy, assignment, and move helps to reduce shared objects
- Regular types promote interoperability of software components, increases productivity as well as quality, security, and performance
- There is no performance penalty to using value semantics, and often times there are performance benefits from a decreased use of the heap

Demo

# Photoshop History

# Photoshop History

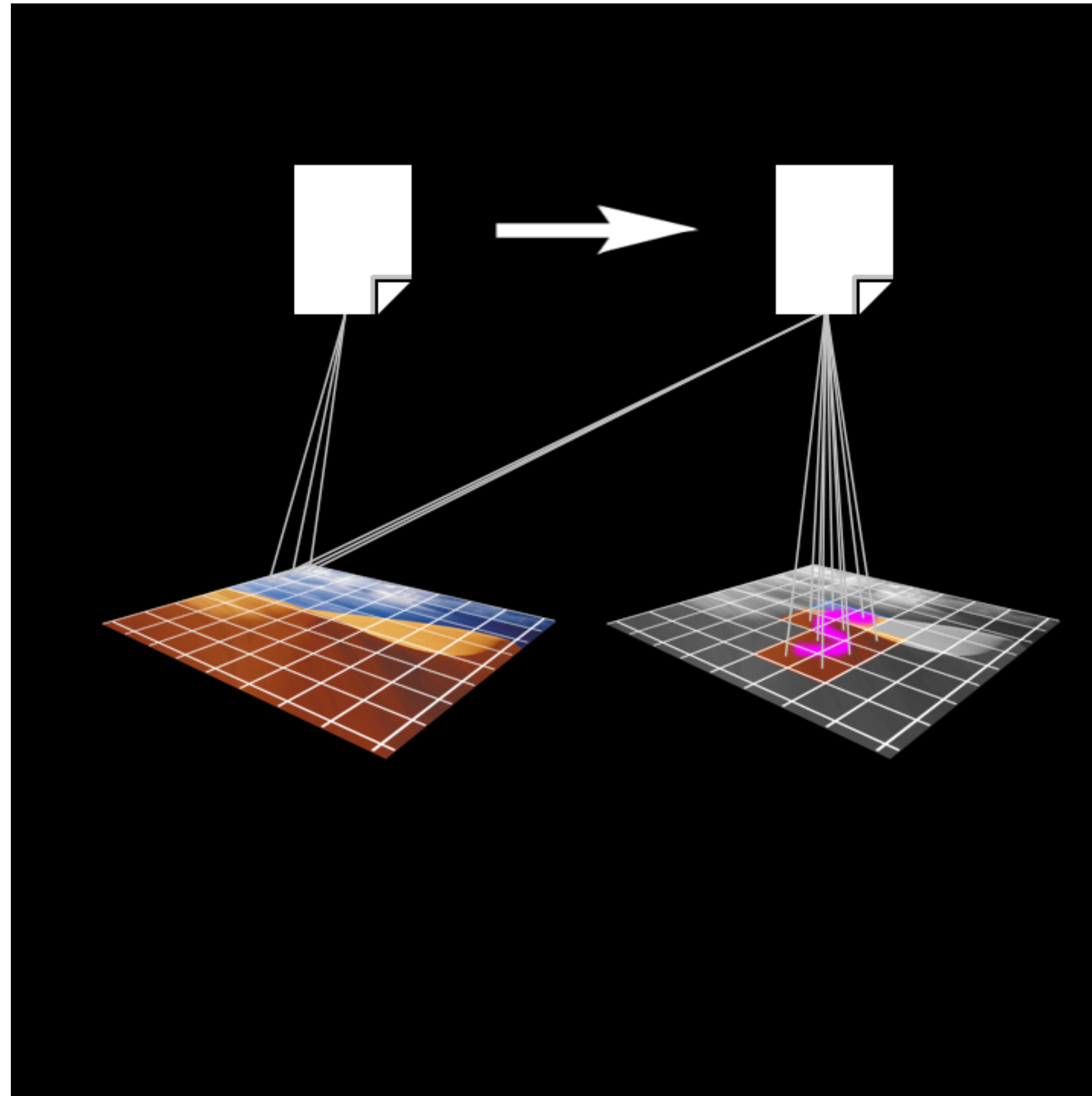

```
{ return make_unique<model>(*this); }
void draw_(ostream& out, size_t position) const override
{ draw(data_, out, position); }

    T data_;
};

unique_ptr<concept_t> self_;
};

using document_t = vector<object_t>;

void draw(const document_t& x, ostream& out, size_t position)
{
    out << string(position, ' ') << "<document>" << endl;
    for (const auto& e: x) draw(e, out, position + 2);
    out << string(position, ' ') << "</document>" << endl;
}
```

```
{ return make_unique<model>(*this); }
void draw_(ostream& out, size_t position) const override
{ draw(data_, out, position); }

    T data_;
};

unique_ptr<concept_t> self_;
};

using document_t = vector<object_t>;

void draw(const document_t& x, ostream& out, size_t position)
{
    out << string(position, ' ') << "<document>" << endl;
    for (const auto& e: x) draw(e, out, position + 2);
    out << string(position, ' ') << "</document>" << endl;
}

using history_t = vector<document_t>;

void commit(history_t& x) { assert(x.size()); x.push_back(x.back()); }
void undo(history_t& x) { assert(x.size()); x.pop_back(); }
document_t& current(history_t& x) { assert(x.size()); return x.back(); }
```

client

library

```
model(T x) : data_(move(x)) { }  
unique_ptr<concept_t> copy_() const override  
{ return make_unique<model>(*this); }  
void draw_(ostream& out, size_t position) const override  
{ draw(data_, out, position); }  
  
T data_;  
};  
  
unique_ptr<concept_t> self_;  
};  
  
using document_t = vector<object_t>;  
  
void draw(const document_t& x, ostream& out, size_t position)  
{  
    out << string(position, ' ') << "<document>" << endl;  
    for (const auto& e: x) draw(e, out, position + 2);  
    out << string(position, ' ') << "</document>" << endl;  
}  
  
using history_t = vector<document_t>;  
  
void commit(history_t& x) { assert(x.size()); x.push_back(x.back()); }  
void undo(history_t& x) { assert(x.size()); x.pop_back(); }
```

cout

guidelines

defects

client

library

```
struct model final : concept_t {  
    model(T x) : data_(move(x)) { }  
    unique_ptr<concept_t> copy_() const override  
    { return make_unique<model>(*this); }  
    void draw_(ostream& out, size_t position) const override  
    { draw(data_, out, position); }  
  
    T data_;  
};  
  
unique_ptr<concept_t> self_;  
};  
  
using document_t = vector<object_t>;  
  
void draw(const document_t& x, ostream& out, size_t position)  
{  
    out << string(position, ' ') << "<document>" << endl;  
    for (const auto& e: x) draw(e, out, position + 2);  
    out << string(position, ' ') << "</document>" << endl;  
}  
  
using history_t = vector<document_t>;  
  
void commit(history_t& x) { assert(x.size()); x.push_back(x.back()); }
```

cout

guidelines

defects

client

library

```
template <typename T>
struct model final : concept_t {
    model(T x) : data_(move(x)) { }
    unique_ptr<concept_t> copy_() const override
    { return make_unique<model>(*this); }
    void draw_(ostream& out, size_t position) const override
    { draw(data_, out, position); }

    T data_;
};

unique_ptr<concept_t> self_;

using document_t = vector<object_t>;

void draw(const document_t& x, ostream& out, size_t position)
{
    out << string(position, ' ') << "<document>" << endl;
    for (const auto& e: x) draw(e, out, position + 2);
    out << string(position, ' ') << "</document>" << endl;
}

using history_t = vector<document_t>;
```

cout

guidelines

defects



client

library

```
};  
template <typename T>  
struct model final : concept_t {  
    model(T x) : data_(move(x)) { }  
    unique_ptr<concept_t> copy_() const override  
    { return make_unique<model>(*this); }  
    void draw_(ostream& out, size_t position) const override  
    { draw(data_, out, position); }  
  
    T data_;  
};  
  
unique_ptr<concept_t> self_;  
};  
  
using document_t = vector<object_t>;  
  
void draw(const document_t& x, ostream& out, size_t position)  
{  
    out << string(position, ' ') << "<document>" << endl;  
    for (const auto& e: x) draw(e, out, position + 2);  
    out << string(position, ' ') << "</document>" << endl;  
}  
  
using history_t = vector<document_t>;
```

cout

guidelines

defects

client

library

```
        virtual void draw_(ostream&, size_t) const = 0;
};
template <typename T>
struct model final : concept_t {
    model(T x) : data_(move(x)) { }
    unique_ptr<concept_t> copy_() const override
    { return make_unique<model>(*this); }
    void draw_(ostream& out, size_t position) const override
    { draw(data_, out, position); }

    T data_;
};

unique_ptr<concept_t> self_;
};

using document_t = vector<object_t>;

void draw(const document_t& x, ostream& out, size_t position)
{
    out << string(position, ' ') << "<document>" << endl;
    for (const auto& e: x) draw(e, out, position + 2);
    out << string(position, ' ') << "</document>" << endl;
}
```

cout

guidelines

defects

client

library

```
virtual unique_ptr<concept_t> copy_() const = 0;
virtual void draw_(ostream&, size_t) const = 0;
};
template <typename T>
struct model final : concept_t {
    model(T x) : data_(move(x)) { }
    unique_ptr<concept_t> copy_() const override
    { return make_unique<model>(*this); }
    void draw_(ostream& out, size_t position) const override
    { draw(data_, out, position); }

    T data_;
};

unique_ptr<concept_t> self_;
};

using document_t = vector<object_t>;

void draw(const document_t& x, ostream& out, size_t position)
{
    out << string(position, ' ') << "<document>" << endl;
    for (const auto& e: x) draw(e, out, position + 2);
    out << string(position, ' ') << "</document>" << endl;
}
```

cout

guidelines

defects

client

library

```
virtual ~concept_t() = default;
virtual unique_ptr<concept_t> copy_() const = 0;
virtual void draw_(ostream&, size_t) const = 0;
};
template <typename T>
struct model final : concept_t {
    model(T x) : data_(move(x)) { }
    unique_ptr<concept_t> copy_() const override
    { return make_unique<model>(*this); }
    void draw_(ostream& out, size_t position) const override
    { draw(data_, out, position); }

    T data_;
};

unique_ptr<concept_t> self_;
};

using document_t = vector<object_t>;

void draw(const document_t& x, ostream& out, size_t position)
{
    out << string(position, ' ') << "<document>" << endl;
    for (const auto& e: x) draw(e, out, position + 2);
    out << string(position, ' ') << "</document>" << endl;
}
```

cout

guidelines

defects

client

library

```
struct concept_t {  
    virtual ~concept_t() = default;  
    virtual unique_ptr<concept_t> copy_() const = 0;  
    virtual void draw_(ostream&, size_t) const = 0;  
};  
template <typename T>  
struct model final : concept_t {  
    model(T x) : data_(move(x)) { }  
    unique_ptr<concept_t> copy_() const override  
    { return make_unique<model>(*this); }  
    void draw_(ostream& out, size_t position) const override  
    { draw(data_, out, position); }  
  
    T data_;  
};  
  
unique_ptr<concept_t> self_;  
};  
  
using document_t = vector<object_t>;  
  
void draw(const document_t& x, ostream& out, size_t position)  
{  
    out << string(position, ' ') << "<document>" << endl;  
    for (const auto& e: x) draw(e, out, position + 2);  
}
```

cout

guidelines

defects

client

library

```
private:
    struct concept_t {
        virtual ~concept_t() = default;
        virtual unique_ptr<concept_t> copy_() const = 0;
        virtual void draw_(ostream&, size_t) const = 0;
    };
    template <typename T>
    struct model final : concept_t {
        model(T x) : data_(move(x)) { }
        unique_ptr<concept_t> copy_() const override
        { return make_unique<model>(*this); }
        void draw_(ostream& out, size_t position) const override
        { draw(data_, out, position); }

        T data_;
    };

    unique_ptr<concept_t> self_;
};

using document_t = vector<object_t>;

void draw(const document_t& x, ostream& out, size_t position)
{
    out << string(position, ' ') << "<document>" << endl;
}
```

cout

guidelines

defects

client

library



```
private:
    struct concept_t {
        virtual ~concept_t() = default;
        virtual unique_ptr<concept_t> copy_() const = 0;
        virtual void draw_(ostream&, size_t) const = 0;
    };
    template <typename T>
    struct model final : concept_t {
        model(T x) : data_(move(x)) { }
        unique_ptr<concept_t> copy_() const override
        { return make_unique<model>(*this); }
        void draw_(ostream& out, size_t position) const override
        { draw(data_, out, position); }

        T data_;
    };

    unique_ptr<concept_t> self_;
};

using document_t = vector<object_t>;

void draw(const document_t& x, ostream& out, size_t position)
{
```



cout

guidelines

defects

client

library

```
{ x.self_>draw_(out, position); }
```

private:

```
struct concept_t {  
    virtual ~concept_t() = default;  
    virtual unique_ptr<concept_t> copy_() const = 0;  
    virtual void draw_(ostream&, size_t) const = 0;  
};  
template <typename T>  
struct model final : concept_t {  
    model(T x) : data_(move(x)) { }  
    unique_ptr<concept_t> copy_() const override  
    { return make_unique<model>(*this); }  
    void draw_(ostream& out, size_t position) const override  
    { draw(data_, out, position); }  
  
    T data_;  
};
```

```
unique_ptr<concept_t> self_;  
};
```

```
using document_t = vector<object_t>;
```

```
void draw(const document_t& x, ostream& out, size_t position)
```

cout

guidelines

defects



client

library

```
friend void draw(const object_t& x, ostream& out, size_t position)
{ x.self_>draw_(out, position); }

private:
struct concept_t {
    virtual ~concept_t() = default;
    virtual unique_ptr<concept_t> copy_() const = 0;
    virtual void draw_(ostream&, size_t) const = 0;
};
template <typename T>
struct model final : concept_t {
    model(T x) : data_(move(x)) { }
    unique_ptr<concept_t> copy_() const override
    { return make_unique<model>(*this); }
    void draw_(ostream& out, size_t position) const override
    { draw(data_, out, position); }

    T data_;
};

unique_ptr<concept_t> self_;
};

using document_t = vector<object_t>;
```

cout

guidelines

defects

client

library



```
friend void draw(const object_t& x, ostream& out, size_t position)
{ x.self_>draw_(out, position); }
```

private:

```
struct concept_t {
    virtual ~concept_t() = default;
    virtual unique_ptr<concept_t> copy_() const = 0;
    virtual void draw_(ostream&, size_t) const = 0;
};
template <typename T>
struct model final : concept_t {
    model(T x) : data_(move(x)) { }
    unique_ptr<concept_t> copy_() const override
    { return make_unique<model>(*this); }
    void draw_(ostream& out, size_t position) const override
    { draw(data_, out, position); }

    T data_;
};
```

```
unique_ptr<concept_t> self_;
};
```

```
using document_t = vector<object_t>;
```



cout

guidelines

defects

client

library

```
object_t& operator=(object_t&&) noexcept = default;

friend void draw(const object_t& x, ostream& out, size_t position)
{ x.self_>draw_(out, position); }

private:
struct concept_t {
    virtual ~concept_t() = default;
    virtual unique_ptr<concept_t> copy_() const = 0;
    virtual void draw_(ostream&, size_t) const = 0;
};
template <typename T>
struct model final : concept_t {
    model(T x) : data_(move(x)) { }
    unique_ptr<concept_t> copy_() const override
    { return make_unique<model>(*this); }
    void draw_(ostream& out, size_t position) const override
    { draw(data_, out, position); }

    T data_;
};

unique_ptr<concept_t> self_;
};
```

cout

guidelines

defects

client

library

```
{ object_t tmp(x); *this = move(tmp); return *this; }  
object_t& operator=(object_t&&) noexcept = default;
```

```
friend void draw(const object_t& x, ostream& out, size_t position)  
{ x.self_->draw_(out, position); }
```

private:

```
struct concept_t {  
    virtual ~concept_t() = default;  
    virtual unique_ptr<concept_t> copy_() const = 0;  
    virtual void draw_(ostream&, size_t) const = 0;  
};
```

```
template <typename T>
```

```
struct model final : concept_t {  
    model(T x) : data_(move(x)) { }  
    unique_ptr<concept_t> copy_() const override  
    { return make_unique<model>(*this); }  
    void draw_(ostream& out, size_t position) const override  
    { draw(data_, out, position); }
```

```
    T data_;
```

```
};
```

```
unique_ptr<concept_t> self_;
```

```
};
```

cout

guidelines

defects

client

library

```
object_t& operator=(const object_t& x)
{ object_t tmp(x); *this = move(tmp); return *this; }
object_t& operator=(object_t&&) noexcept = default;

friend void draw(const object_t& x, ostream& out, size_t position)
{ x.self_>draw_(out, position); }
```

private:

```
struct concept_t {
    virtual ~concept_t() = default;
    virtual unique_ptr<concept_t> copy_() const = 0;
    virtual void draw_(ostream&, size_t) const = 0;
};

template <typename T>
struct model final : concept_t {
    model(T x) : data_(move(x)) { }
    unique_ptr<concept_t> copy_() const override
    { return make_unique<model>(*this); }
    void draw_(ostream& out, size_t position) const override
    { draw(data_, out, position); }

    T data_;
};
```

```
unique_ptr<concept_t> self_;
```

cout

guidelines

defects



```
object_t& operator=(const object_t& x)
{ object_t tmp(x); *this = move(tmp); return *this; }
object_t& operator=(object_t&&) noexcept = default;

friend void draw(const object_t& x, ostream& out, size_t position)
{ x.self_->draw_(out, position); }
```

private:

```
struct concept_t {
    virtual ~concept_t() = default;
    virtual unique_ptr<concept_t> copy_() const = 0;
    virtual void draw_(ostream&, size_t) const = 0;
};
template <typename T>
struct model final : concept_t {
    model(T x) : data_(move(x)) { }
    unique_ptr<concept_t> copy_() const override
    { return make_unique<model>(*this); }
    void draw_(ostream& out, size_t position) const override
    { draw(data_, out, position); }

    T data_;
};
```



```
object_t(object_t&&) noexcept = default;

object_t& operator=(const object_t& x)
{ object_t tmp(x); *this = move(tmp); return *this; }
object_t& operator=(object_t&&) noexcept = default;

friend void draw(const object_t& x, ostream& out, size_t position)
{ x.self_->draw_(out, position); }

private:
struct concept_t {
    virtual ~concept_t() = default;
    virtual unique_ptr<concept_t> copy_() const = 0;
    virtual void draw_(ostream&, size_t) const = 0;
};
template <typename T>
struct model final : concept_t {
    model(T x) : data_(move(x)) { }
    unique_ptr<concept_t> copy_() const override
    { return make_unique<model>(*this); }
    void draw_(ostream& out, size_t position) const override
    { draw(data_, out, position); }

    T data_;
};
```

client

library

```
{ }  
object_t(object_t&&) noexcept = default;  
  
object_t& operator=(const object_t& x)  
{ object_t tmp(x); *this = move(tmp); return *this; }  
object_t& operator=(object_t&&) noexcept = default;  
  
friend void draw(const object_t& x, ostream& out, size_t position)  
{ x.self_->draw_(out, position); }  
  
private:  
struct concept_t {  
    virtual ~concept_t() = default;  
    virtual unique_ptr<concept_t> copy_() const = 0;  
    virtual void draw_(ostream&, size_t) const = 0;  
};  
template <typename T>  
struct model final : concept_t {  
    model(T x) : data_(move(x)) { }  
    unique_ptr<concept_t> copy_() const override  
    { return make_unique<model>(*this); }  
    void draw_(ostream& out, size_t position) const override  
    { draw(data_, out, position); }  
  
    T data_;
```

cout

guidelines

defects



client

library

```
object_t(const object_t& x) : self_(x.self_>copy_())
{ }
object_t(object_t&&) noexcept = default;

object_t& operator=(const object_t& x)
{ object_t tmp(x); *this = move(tmp); return *this; }
object_t& operator=(object_t&&) noexcept = default;

friend void draw(const object_t& x, ostream& out, size_t position)
{ x.self_>draw_(out, position); }

private:
struct concept_t {
    virtual ~concept_t() = default;
    virtual unique_ptr<concept_t> copy_() const = 0;
    virtual void draw_(ostream&, size_t) const = 0;
};
template <typename T>
struct model final : concept_t {
    model(T x) : data_(move(x)) { }
    unique_ptr<concept_t> copy_() const override
    { return make_unique<model>(*this); }
    void draw_(ostream& out, size_t position) const override
    { draw(data_, out, position); }
```

cout

guidelines

defects

client

library



```
object_t(const object_t& x) : self_(x.self_>copy_())
{ }
object_t(object_t&&) noexcept = default;

object_t& operator=(const object_t& x)
{ object_t tmp(x); *this = move(tmp); return *this; }
object_t& operator=(object_t&&) noexcept = default;

friend void draw(const object_t& x, ostream& out, size_t position)
{ x.self_>draw_(out, position); }
```

private:

```
struct concept_t {
    virtual ~concept_t() = default;
    virtual unique_ptr<concept_t> copy_() const = 0;
    virtual void draw_(ostream&, size_t) const = 0;
};

template <typename T>
struct model final : concept_t {
    model(T x) : data_(move(x)) { }
    unique_ptr<concept_t> copy_() const override
    { return make_unique<model>(*this); }
    void draw_(ostream& out, size_t position) const override
    { draw(data_, out, position); }
```



cout

guidelines

defects

```
{ }

object_t(const object_t& x) : self_(x.self_>copy_())
{ }
object_t(object_t&&) noexcept = default;

object_t& operator=(const object_t& x)
{ object_t tmp(x); *this = move(tmp); return *this; }
object_t& operator=(object_t&&) noexcept = default;

friend void draw(const object_t& x, ostream& out, size_t position)
{ x.self_>draw_(out, position); }

private:
struct concept_t {
    virtual ~concept_t() = default;
    virtual unique_ptr<concept_t> copy_() const = 0;
    virtual void draw_(ostream&, size_t) const = 0;
};
template <typename T>
struct model final : concept_t {
    model(T x) : data_(move(x)) { }
    unique_ptr<concept_t> copy_() const override
    { return make_unique<model>(*this); }
    void draw_(ostream& out, size_t position) const override
```

client

library

```
object_t(T x) : self_(make_unique<model<T>>(move(x)))
{ }

object_t(const object_t& x) : self_(x.self_>copy_())
{ }
object_t(object_t&&) noexcept = default;

object_t& operator=(const object_t& x)
{ object_t tmp(x); *this = move(tmp); return *this; }
object_t& operator=(object_t&&) noexcept = default;

friend void draw(const object_t& x, ostream& out, size_t position)
{ x.self_>draw_(out, position); }

private:
struct concept_t {
    virtual ~concept_t() = default;
    virtual unique_ptr<concept_t> copy_() const = 0;
    virtual void draw_(ostream&, size_t) const = 0;
};
template <typename T>
struct model final : concept_t {
    model(T x) : data_(move(x)) { }
    unique_ptr<concept_t> copy_() const override
    { return make_unique<model>(*this); }
```

cout

guidelines

defects

client

library

```
template <typename T>
object_t(T x) : self_(make_unique<model<T>>(move(x)))
{ }

object_t(const object_t& x) : self_(x.self_->copy_())
{ }
object_t(object_t&&) noexcept = default;

object_t& operator=(const object_t& x)
{ object_t tmp(x); *this = move(tmp); return *this; }
object_t& operator=(object_t&&) noexcept = default;

friend void draw(const object_t& x, ostream& out, size_t position)
{ x.self_->draw_(out, position); }

private:
struct concept_t {
    virtual ~concept_t() = default;
    virtual unique_ptr<concept_t> copy_() const = 0;
    virtual void draw_(ostream&, size_t) const = 0;
};
template <typename T>
struct model final : concept_t {
    model(T x) : data_(move(x)) { }
    unique_ptr<concept_t> copy_() const override
```

cout

guidelines

defects

```
public:
    template <typename T>
    object_t(T x) : self_(make_unique<model<T>>(move(x)))
    { }

    object_t(const object_t& x) : self_(x.self_>copy_())
    { }
    object_t(object_t&&) noexcept = default;

    object_t& operator=(const object_t& x)
    { object_t tmp(x); *this = move(tmp); return *this; }
    object_t& operator=(object_t&&) noexcept = default;

    friend void draw(const object_t& x, ostream& out, size_t position)
    { x.self_>draw_(out, position); }

private:
    struct concept_t {
        virtual ~concept_t() = default;
        virtual unique_ptr<concept_t> copy_() const = 0;
        virtual void draw_(ostream&, size_t) const = 0;
    };
    template <typename T>
    struct model final : concept_t {
        model(T x) : data_(move(x)) { }
```

client

library

```
class object_t {  
    public:  
        template <typename T>  
        object_t(T x) : self_(make_unique<model<T>>(move(x)))  
        { }  
  
        object_t(const object_t& x) : self_(x.self_>copy_())  
        { }  
        object_t(object_t&&) noexcept = default;  
  
        object_t& operator=(const object_t& x)  
        { object_t tmp(x); *this = move(tmp); return *this; }  
        object_t& operator=(object_t&&) noexcept = default;  
  
        friend void draw(const object_t& x, ostream& out, size_t position)  
        { x.self_>draw_(out, position); }  
  
    private:  
        struct concept_t {  
            virtual ~concept_t() = default;  
            virtual unique_ptr<concept_t> copy_() const = 0;  
            virtual void draw_(ostream&, size_t) const = 0;  
        };  
        template <typename T>  
        struct model final : concept_t {
```

cout

guidelines

defects

client

library

```
class object_t {  
    public:  
        template <typename T>  
        object_t(T x) : self_(make_unique<model<T>>(move(x)))  
        { }  
  
        object_t(const object_t& x) : self_(x.self_>copy_())  
        { }  
        object_t(object_t&&) noexcept = default;  
  
        object_t& operator=(const object_t& x)  
        { object_t tmp(x); *this = move(tmp); return *this; }  
        object_t& operator=(object_t&&) noexcept = default;  
  
        friend void draw(const object_t& x, ostream& out, size_t position)  
        { x.self_>draw_(out, position); }  
  
    private:  
        struct concept_t {  
            virtual ~concept_t() = default;  
            virtual unique_ptr<concept_t> copy_() const = 0;  
            virtual void draw_(ostream&, size_t) const = 0;  
        };  
        template <typename T>  
        struct model final : concept_t {
```

cout

guidelines

defects



```
class object_t {  
    public:  
        template <typename T>  
        object_t(T x) : self_(make_unique<model<T>>(move(x)))  
        { }  
  
        object_t(const object_t& x) : self_(x.self_>copy ())  
        { cout << "copy" << endl; }  
        object_t(object_t&&) noexcept = default;  
  
        object_t& operator=(const object_t& x)  
        { object_t tmp(x); *this = move(tmp); return *this; }  
        object_t& operator=(object_t&&) noexcept = default;  
  
        friend void draw(const object_t& x, ostream& out, size_t position)  
        { x.self_>draw_(out, position); }  
  
    private:  
        struct concept_t {  
            virtual ~concept_t() = default;  
            virtual unique_ptr<concept_t> copy_() const = 0;  
            virtual void draw_(ostream&, size_t) const = 0;  
        };  
        template <typename T>  
        struct model final : concept_t {
```

```
class my_class_t {
    /* ... */
};

void draw(const my_class_t&, ostream& out, size_t position)
{ out << string(position, ' ') << "my_class_t" << endl; }

int main()
{
    document_t document;

    document.emplace_back(0);
    document.emplace_back(string("Hello!"));
    document.emplace_back(document);
    document.emplace_back(my_class_t());

    draw(document, cout, 0);
}
```

client

library



```
    /* ... */  
};  
  
void draw(const my_class_t&, ostream& out, size_t position)  
{ out << string(position, ' ') << "my_class_t" << endl; }  
  
int main()  
{  
    document_t document;  
  
    document.emplace_back(0);  
    document.emplace_back(string("Hello!"));  
    document.emplace_back(document);  
    document.emplace_back(my_class_t());  
  
    draw(document, cout, 0);  
}
```

cout

guidelines

defects

client

library

```
};
```



```
void draw(const my_class_t&, ostream& out, size_t position)
{ out << string(position, ' ') << "my_class_t" << endl; }
```

```
int main()
{
    document_t document;

    document.emplace_back(0);
    document.emplace_back(string("Hello!"));
    document.emplace_back(document);
    document.emplace_back(my_class_t());

    draw(document, cout, 0);
}
```

cout

guidelines

defects

client

library



```
void draw(const my_class_t&, ostream& out, size_t position)
{ out << string(position, ' ') << "my_class_t" << endl; }
```

```
int main()
{
    document_t document;

    document.emplace_back(0);
    document.emplace_back(string("Hello!"));
    document.emplace_back(document);
    document.emplace_back(my_class_t());

    draw(document, cout, 0);
}
```

cout

guidelines

defects

client

library

```
void draw(const my_class_t&, ostream& out, size_t position)
{ out << string(position, ' ') << "my_class_t" << endl; }
```

```
int main()
{
    document_t document;

    document.emplace_back(0);
    document.emplace_back(string("Hello!"));
    document.emplace_back(document);
    document.emplace_back(my_class_t());

    draw(document, cout, 0);
}
```

cout

guidelines

defects

client

library

```
{ out << string(position, ' ') << "my_class_t" << endl; }
```

```
int main()
{
    document_t document;

    document.emplace_back(0);
    document.emplace_back(string("Hello!"));
    document.emplace_back(document);
    document.emplace_back(my_class_t());

    draw(document, cout, 0);
}
```

cout

guidelines

defects

client

library



```
int main()
{
    document_t document;

    document.emplace_back(0);
    document.emplace_back(string("Hello!"));
    document.emplace_back(document);
    document.emplace_back(my_class_t());

    draw(document, cout, 0);
}
```

cout

guidelines

defects



client

library



```
int main()
{
    document_t document;

    document.emplace_back(0);
    document.emplace_back(string("Hello!"));
    document.emplace_back(document);
    document.emplace_back(my_class_t());

    draw(document, cout, 0);
}
```

cout

guidelines

defects



```
int main()
{
    history_t h(1);

    current(h).emplace_back(0);
    current(h).emplace_back(string("Hello!"));

    draw(current(h), cout, 0);
    cout << "-----" << endl;

    commit(h);

    current(h)[0] = 42.5;
    current(h)[1] = string("World");
    current(h).emplace_back(current(h));
    current(h).emplace_back(my_class_t());

    draw(current(h), cout, 0);
    cout << "-----" << endl;

    undo(h);

    draw(current(h), cout, 0);
}
```



```
int main()
{
    history_t h(1);

    current(h).emplace_back(0);
    current(h).emplace_back(string("Hello!"));

    draw(current(h), cout, 0);
    cout << "-----" << endl;

    commit(h);

    current(h)[0] = 42.5;
    current(h)[1] = string("World");
    current(h).emplace_back(current(h));
    current(h).emplace_back(my_class_t());

    draw(current(h), cout, 0);
    cout << "-----" << endl;

    undo(h);

    draw(current(h), cout, 0);
}
```

```
class object_t {  
    public:  
        template <typename T>  
        object_t(T x) : self_(make_unique<model<T>>(move(x)))  
        { }
```

```
        object_t(const object_t& x) : self_(x.self_>copy_())  
        { cout << "copy" << endl; }  
        object_t(object_t&&) noexcept = default;  
  
        object_t& operator=(const object_t& x)  
        { object_t tmp(x); *this = move(tmp); return *this; }  
        object_t& operator=(object_t&&) noexcept = default;
```

```
        friend void draw(const object_t& x, ostream& out, size_t position)  
        { x.self_>draw_(out, position); }
```

```
private:  
    struct concept_t {  
        virtual ~concept_t() = default;  
        virtual unique_ptr<concept_t> copy_() const = 0;  
        virtual void draw_(ostream&, size_t) const = 0;  
    };  
    template <typename T>  
    struct model final : concept_t {
```

```
class object_t {  
public:  
    template <typename T>  
    object_t(T x) : self_(make_unique<model<T>>(move(x)))  
    { }  
  
    friend void draw(const object_t& x, ostream& out, size_t position)  
    { x.self_>draw_(out, position); }  
  
private:  
    struct concept_t {  
        virtual ~concept_t() = default;  
        virtual unique_ptr<concept_t> copy_() const = 0;  
        virtual void draw_(ostream&, size_t) const = 0;  
    };  
    template <typename T>  
    struct model final : concept_t {  
        model(T x) : data_(move(x)) { }  
        unique_ptr<concept_t> copy_() const override  
        { return make_unique<model>(*this); }  
        void draw_(ostream& out, size_t position) const override  
        { draw(data_, out, position); }  
  
        T data_;  
    };
```

```
class object_t {  
    public:  
        template <typename T>  
        object_t(T x) : self_(make_unique<model<T>>(move(x)))  
        { }  
  
        friend void draw(const object_t& x, ostream& out, size_t position)  
        { x.self_>draw_(out, position); }  
  
    private:  
        struct concept_t {  
            virtual ~concept_t() = default;  
            virtual unique_ptr<concept_t> copy_() const = 0;  
            virtual void draw_(ostream&, size_t) const = 0;  
        };  
        template <typename T>  
        struct model final : concept_t {  
            model(T x) : data_(move(x)) { }  
            unique_ptr<concept_t> copy_() const override  
            { return make_unique<model>(*this); }  
            void draw_(ostream& out, size_t position) const override  
            { draw(data_, out, position); }  
  
            T data_;  
        };  
};
```

```
class object_t {  
    public:  
        template <typename T>  
        object_t(T x) : self_(make_unique<model<T>>(move(x)))  
        { }  
  
        friend void draw(const object_t& x, ostream& out, size_t position)  
        { x.self_>draw_(out, position); }  
  
    private:  
        struct concept_t {  
            virtual ~concept_t() = default;  
            virtual void draw_(ostream&, size_t) const = 0;  
        };  
        template <typename T>  
        struct model final : concept_t {  
            model(T x) : data_(move(x)) { }  
            void draw_(ostream& out, size_t position) const override  
            { draw(data_, out, position); }  
  
            T data_;  
        };  
  
        unique_ptr<concept_t> self_;  
};
```

```
class object_t {  
    public:  
        template <typename T>  
        object_t(T x) : self_(make_unique<model<T>>(move(x)))  
        { }  
  
        friend void draw(const object_t& x, ostream& out, size_t position)  
        { x.self_>draw_(out, position); }  
  
    private:  
        struct concept_t {  
            virtual ~concept_t() = default;  
            virtual void draw_(ostream&, size_t) const = 0;  
        };  
        template <typename T>  
        struct model final : concept_t {  
            model(T x) : data_(move(x)) { }  
            void draw_(ostream& out, size_t position) const override  
            { draw(data_, out, position); }  
  
            T data_;  
        };  
  
        shared_ptr<concept_t> self_;  
};
```



```
class object_t {  
    public:  
        template <typename T>  
        object_t(T x) : self_(make_unique<model<T>>(move(x)))  
        { }  
  
        friend void draw(const object_t& x, ostream& out, size_t position)  
        { x.self_->draw_(out, position); }  
  
    private:  
        struct concept_t {  
            virtual ~concept_t() = default;  
            virtual void draw_(ostream&, size_t) const = 0;  
        };  
        template <typename T>  
        struct model final : concept_t {  
            model(T x) : data_(move(x)) { }  
            void draw_(ostream& out, size_t position) const override  
            { draw(data_, out, position); }  
  
            T data_;  
        };  
  
        shared_ptr<const concept_t> self_;  
};
```

```
class object_t {  
    public:  
        template <typename T>  
        object_t(T x) : self_(make_unique<model<T>>(move(x)))  
        { }  
  
        friend void draw(const object_t& x, ostream& out, size_t position)  
        { x.self_>draw_(out, position); }  
  
    private:  
        struct concept_t {  
            virtual ~concept_t() = default;  
            virtual void draw_(ostream&, size_t) const = 0;  
        };  
        template <typename T>  
        struct model final : concept_t {  
            model(T x) : data_(move(x)) { }  
            void draw_(ostream& out, size_t position) const override  
            { draw(data_, out, position); }  
  
            T data_;  
        };  
  
        shared_ptr<const concept_t> self_;  
};
```

```
class object_t {  
    public:  
        template <typename T>  
        object_t(T x) : self_(make_shared<model<T>>(move(x)))  
        { }  
  
        friend void draw(const object_t& x, ostream& out, size_t position)  
        { x.self_>draw_(out, position); }  
  
    private:  
        struct concept_t {  
            virtual ~concept_t() = default;  
            virtual void draw_(ostream&, size_t) const = 0;  
        };  
        template <typename T>  
        struct model final : concept_t {  
            model(T x) : data_(move(x)) { }  
            void draw_(ostream& out, size_t position) const override  
            { draw(data_, out, position); }  
  
            T data_;  
        };  
  
        shared_ptr<const concept_t> self_;  
};
```



```
int main()
{
    history_t h(1);

    current(h).emplace_back(0);
    current(h).emplace_back(string("Hello!"));

    draw(current(h), cout, 0);
    cout << "-----" << endl;

    commit(h);

    current(h)[0] = 42.5;
    current(h)[1] = string("World");
    current(h).emplace_back(current(h));
    current(h).emplace_back(my_class_t());

    draw(current(h), cout, 0);
    cout << "-----" << endl;

    undo(h);

    draw(current(h), cout, 0);
}
```



```
int main()
{
    history_t h(1);

    current(h).emplace_back(0);
    current(h).emplace_back(string("Hello!"));

    draw(current(h), cout, 0);
    cout << "-----" << endl;

    commit(h);

    current(h)[0] = 42.5;
```

```
auto saving = async([document = current(h)]() {
    this_thread::sleep_for(chrono::seconds(3));
    cout << "----- 'save' -----" << endl;
    draw(document, cout, 0);
});
```

```
current(h)[1] = string("World");
----- 'save' -----
current(h).emplace_back(current(h));
<document>.emplace_back(my_class_t());
```

**42.5**

**Hello!**

</document>

# Compared To Inheritance Based Design

- More flexible
  - Non-intrusive design doesn't require class wrappers
- More efficient
  - Polymorphism is only paid for when needed
- Less error prone
  - Client doesn't do any heap allocation, worry about object ownership or lifetimes
  - Exception safe
- Thread safe

```
template <typename T>
void draw(const T& x, ostream& out, size_t position)
{ out << string(position, ' ') << x << endl; }

class object_t {
public:
    template <typename T>
    object_t(T x) : self_(make_shared<model<T>>(move(x)))
    { }

    friend void draw(const object_t& x, ostream& out, size_t position)
    { x.self_->draw_(out, position); }

private:
    struct concept_t {
        virtual ~concept_t() = default;
        virtual void draw_(ostream&, size_t) const = 0;
    };
    template <typename T>
    struct model final : concept_t {
        model(T x) : data_(move(x)) { }
        void draw_(ostream& out, size_t position) const override
        { draw(data_, out, position); }

        T data_;
    };
};
```

client

library

```
void draw(const T& x, ostream& out, size_t position)
{ out << string(position, ' ') << x << endl; }

class object_t {
public:
    template <typename T>
    object_t(T x) : self_(make_shared<model<T>>(move(x)))
    { }

    friend void draw(const object_t& x, ostream& out, size_t position)
    { x.self_->draw_(out, position); }

private:
    struct concept_t {
        virtual ~concept_t() = default;
        virtual void draw_(ostream&, size_t) const = 0;
    };
    template <typename T>
    struct model final : concept_t {
        model(T x) : data_(move(x)) { }
        void draw_(ostream& out, size_t position) const override
        { draw(data_, out, position); }

        T data_;
    };
};
```

cout

guidelines

defects



client

library

```
{ out << string(position, ' ') << x << endl; }
```

```
class object_t {  
public:  
    template <typename T>  
    object_t(T x) : self_(make_shared<model<T>>(move(x)))  
    { }  
  
    friend void draw(const object_t& x, ostream& out, size_t position)  
    { x.self_->draw_(out, position); }  
  
private:  
    struct concept_t {  
        virtual ~concept_t() = default;  
        virtual void draw_(ostream&, size_t) const = 0;  
    };  
    template <typename T>  
    struct model final : concept_t {  
        model(T x) : data_(move(x)) { }  
        void draw_(ostream& out, size_t position) const override  
        { draw(data_, out, position); }  
  
        T data_;  
    };
```

cout

guidelines

defects

client

library



```
class object_t {
public:
    template <typename T>
    object_t(T x) : self_(make_shared<model<T>>(move(x)))
    { }

    friend void draw(const object_t& x, ostream& out, size_t position)
    { x.self_->draw_(out, position); }

private:
    struct concept_t {
        virtual ~concept_t() = default;
        virtual void draw_(ostream&, size_t) const = 0;
    };
    template <typename T>
    struct model final : concept_t {
        model(T x) : data_(move(x)) { }
        void draw_(ostream& out, size_t position) const override
        { draw(data_, out, position); }

        T data_;
    };

    shared_ptr<const concept_t> self_;
```



cout

guidelines

defects

client

library

```
class object_t {  
    public:  
        template <typename T>  
        object_t(T x) : self_(make_shared<model<T>>(move(x)))  
        { }  
  
        friend void draw(const object_t& x, ostream& out, size_t position)  
        { x.self_->draw_(out, position); }  
  
    private:  
        struct concept_t {  
            virtual ~concept_t() = default;  
            virtual void draw_(ostream&, size_t) const = 0;  
        };  
        template <typename T>  
        struct model final : concept_t {  
            model(T x) : data_(move(x)) { }  
            void draw_(ostream& out, size_t position) const override  
            { draw(data_, out, position); }  
  
            T data_;  
        };  
  
        shared_ptr<const concept_t> self_;  
};
```

cout

guidelines

defects

client

library

```
public:  
    template <typename T>  
    object_t(T x) : self_(make_shared<model<T>>(move(x)))  
    { }  
  
    friend void draw(const object_t& x, ostream& out, size_t position)  
    { x.self_>draw_(out, position); }  
  
private:  
    struct concept_t {  
        virtual ~concept_t() = default;  
        virtual void draw_(ostream&, size_t) const = 0;  
    };  
    template <typename T>  
    struct model final : concept_t {  
        model(T x) : data_(move(x)) { }  
        void draw_(ostream& out, size_t position) const override  
        { draw(data_, out, position); }  
  
        T data_;  
    };  
    shared_ptr<const concept_t> self_;  
};
```

cout

guidelines

defects

client

library

```
template <typename T>
object_t(T x) : self_(make_shared<model<T>>(move(x)))
{ }

friend void draw(const object_t& x, ostream& out, size_t position)
{ x.self_->draw_(out, position); }

private:
struct concept_t {
    virtual ~concept_t() = default;
    virtual void draw_(ostream&, size_t) const = 0;
};
template <typename T>
struct model final : concept_t {
    model(T x) : data_(move(x)) { }
    void draw_(ostream& out, size_t position) const override
    { draw(data_, out, position); }

    T data_;
};

shared_ptr<const concept_t> self_;
};

using document_t = vector<object_t>;
```

cout

guidelines

defects

client

library

```
object_t(T x) : self_(make_shared<model<T>>(move(x)))
{ }

friend void draw(const object_t& x, ostream& out, size_t position)
{ x.self_->draw_(out, position); }

private:
struct concept_t {
    virtual ~concept_t() = default;
    virtual void draw_(ostream&, size_t) const = 0;
};
template <typename T>
struct model final : concept_t {
    model(T x) : data_(move(x)) { }
    void draw_(ostream& out, size_t position) const override
    { draw(data_, out, position); }

    T data_;
};

shared_ptr<const concept_t> self_;
};

using document_t = vector<object_t>;
```

cout

guidelines

defects

client

library

```
{ }  
  
friend void draw(const object_t& x, ostream& out, size_t position)  
{ x.self_>draw_(out, position); }  
  
private:  
struct concept_t {  
    virtual ~concept_t() = default;  
    virtual void draw_(ostream&, size_t) const = 0;  
};  
template <typename T>  
struct model final : concept_t {  
    model(T x) : data_(move(x)) { }  
    void draw_(ostream& out, size_t position) const override  
    { draw(data_, out, position); }  
  
    T data_;  
};  
  
shared_ptr<const concept_t> self_;  
};  
  
using document_t = vector<object_t>;  
  
void draw(const document_t& x, ostream& out, size_t position)
```

cout

guidelines

defects



```
friend void draw(const object_t& x, ostream& out, size_t position)
{ x.self_>draw_(out, position); }

private:
struct concept_t {
    virtual ~concept_t() = default;
    virtual void draw_(ostream&, size_t) const = 0;
};
template <typename T>
struct model final : concept_t {
    model(T x) : data_(move(x)) { }
    void draw_(ostream& out, size_t position) const override
    { draw(data_, out, position); }

    T data_;
};

shared_ptr<const concept_t> self_;
};

using document_t = vector<object_t>;

void draw(const document_t& x, ostream& out, size_t position)
{
```





client

library

```
friend void draw(const object_t& x, ostream& out, size_t position)
{ x.self_>draw_(out, position); }

private:
struct concept_t {
    virtual ~concept_t() = default;
    virtual void draw_(ostream&, size_t) const = 0;
};
template <typename T>
struct model final : concept_t {
    model(T x) : data_(move(x)) { }
    void draw_(ostream& out, size_t position) const override
    { draw(data_, out, position); }

    T data_;
};

shared_ptr<const concept_t> self_;
};

using document_t = vector<object_t>;

void draw(const document_t& x, ostream& out, size_t position)
{
    out << string(position, ' ') << "<document>" << endl;
}
```

cout

guidelines

defects

client

library

```
{ x.self_>draw_(out, position); }
```

private:

```
struct concept_t {  
    virtual ~concept_t() = default;  
    virtual void draw_(ostream&, size_t) const = 0;  
};  
template <typename T>  
struct model final : concept_t {  
    model(T x) : data_(move(x)) { }  
    void draw_(ostream& out, size_t position) const override  
    { draw(data_, out, position); }  
  
    T data_;  
};
```

```
shared_ptr<const concept_t> self_;  
};
```

```
using document_t = vector<object_t>;
```

```
void draw(const document_t& x, ostream& out, size_t position)  
{  
    out << string(position, ' ') << "<document>" << endl;  
    for (const auto& e: x) draw(e, out, position + 2);  
}
```

cout

guidelines

defects

client

library



```
private:
    struct concept_t {
        virtual ~concept_t() = default;
        virtual void draw_(ostream&, size_t) const = 0;
    };
    template <typename T>
    struct model final : concept_t {
        model(T x) : data_(move(x)) { }
        void draw_(ostream& out, size_t position) const override
        { draw(data_, out, position); }

        T data_;
    };

    shared_ptr<const concept_t> self_;
};

using document_t = vector<object_t>;

void draw(const document_t& x, ostream& out, size_t position)
{
    out << string(position, ' ') << "<document>" << endl;
    for (const auto& e: x) draw(e, out, position + 2);
    out << string(position, ' ') << "</document>" << endl;
```



cout

guidelines

defects

client

library

```
private:
    struct concept_t {
        virtual ~concept_t() = default;
        virtual void draw_(ostream&, size_t) const = 0;
    };
    template <typename T>
    struct model final : concept_t {
        model(T x) : data_(move(x)) { }
        void draw_(ostream& out, size_t position) const override
        { draw(data_, out, position); }

        T data_;
    };

    shared_ptr<const concept_t> self_;
};

using document_t = vector<object_t>;

void draw(const document_t& x, ostream& out, size_t position)
{
    out << string(position, ' ') << "<document>" << endl;
    for (const auto& e: x) draw(e, out, position + 2);
    out << string(position, ' ') << "</document>" << endl;
}
```

cout

guidelines

defects

client

library

```
struct concept_t {  
    virtual ~concept_t() = default;  
    virtual void draw_(ostream&, size_t) const = 0;  
};  
template <typename T>  
struct model final : concept_t {  
    model(T x) : data_(move(x)) { }  
    void draw_(ostream& out, size_t position) const override  
    { draw(data_, out, position); }  
  
    T data_;  
};  
  
shared_ptr<const concept_t> self_;  
};  
  
using document_t = vector<object_t>;  
  
void draw(const document_t& x, ostream& out, size_t position)  
{  
    out << string(position, ' ') << "<document>" << endl;  
    for (const auto& e: x) draw(e, out, position + 2);  
    out << string(position, ' ') << "</document>" << endl;  
}
```

cout

guidelines

defects

client

library

```
    virtual ~concept_t() = default;
    virtual void draw_(ostream&, size_t) const = 0;
};
template <typename T>
struct model final : concept_t {
    model(T x) : data_(move(x)) { }
    void draw_(ostream& out, size_t position) const override
    { draw(data_, out, position); }

    T data_;
};

shared_ptr<const concept_t> self_;
};

using document_t = vector<object_t>;

void draw(const document_t& x, ostream& out, size_t position)
{
    out << string(position, ' ') << "<document>" << endl;
    for (const auto& e: x) draw(e, out, position + 2);
    out << string(position, ' ') << "</document>" << endl;
}

using history_t = vector<document_t>;
```

cout

guidelines

defects

client

library

```
        virtual void draw_(ostream&, size_t) const = 0;
};
template <typename T>
struct model final : concept_t {
    model(T x) : data_(move(x)) { }
    void draw_(ostream& out, size_t position) const override
    { draw(data_, out, position); }

    T data_;
};

shared_ptr<const concept_t> self_;
};

using document_t = vector<object_t>;

void draw(const document_t& x, ostream& out, size_t position)
{
    out << string(position, ' ') << "<document>" << endl;
    for (const auto& e: x) draw(e, out, position + 2);
    out << string(position, ' ') << "</document>" << endl;
}

using history_t = vector<document_t>;
```

cout

guidelines

defects

client

library

```
};  
template <typename T>  
struct model final : concept_t {  
    model(T x) : data_(move(x)) { }  
    void draw_(ostream& out, size_t position) const override  
    { draw(data_, out, position); }  
  
    T data_;  
};  
  
shared_ptr<const concept_t> self_;  
};  
  
using document_t = vector<object_t>;  
  
void draw(const document_t& x, ostream& out, size_t position)  
{  
    out << string(position, ' ') << "<document>" << endl;  
    for (const auto& e: x) draw(e, out, position + 2);  
    out << string(position, ' ') << "</document>" << endl;  
}  
  
using history_t = vector<document_t>;  
  
void commit(history_t& x) { assert(x.size()); x.push_back(x.back()); }
```

cout

guidelines

defects



client

library

```
template <typename T>
struct model final : concept_t {
    model(T x) : data_(move(x)) { }
    void draw_(ostream& out, size_t position) const override
    { draw(data_, out, position); }

    T data_;
};

shared_ptr<const concept_t> self_;

using document_t = vector<object_t>;

void draw(const document_t& x, ostream& out, size_t position)
{
    out << string(position, ' ') << "<document>" << endl;
    for (const auto& e: x) draw(e, out, position + 2);
    out << string(position, ' ') << "</document>" << endl;
}

using history_t = vector<document_t>;

void commit(history_t& x) { assert(x.size()); x.push_back(x.back()); }
void undo(history_t& x) { assert(x.size()); x.pop_back(); }
```

cout

guidelines

defects

```
struct model final : concept_t {  
    model(T x) : data_(move(x)) { }  
    void draw_(ostream& out, size_t position) const override  
    { draw(data_, out, position); }  
  
    T data_;  
};  
  
shared_ptr<const concept_t> self_;  
};  
  
using document_t = vector<object_t>;  
  
void draw(const document_t& x, ostream& out, size_t position)  
{  
    out << string(position, ' ') << "<document>" << endl;  
    for (const auto& e: x) draw(e, out, position + 2);  
    out << string(position, ' ') << "</document>" << endl;  
}  
  
using history_t = vector<document_t>;  
  
void commit(history_t& x) { assert(x.size()); x.push_back(x.back()); }  
void undo(history_t& x) { assert(x.size()); x.pop_back(); }  
document_t& current(history_t& x) { assert(x.size()); return x.back(); }
```

# Concluding Remarks

- As we increasingly move to heavily threaded systems using promises, reactive programming, and task queues, value semantics becomes critical to avoid locking and to reason about code
- It is my hope that the language (and libraries) will evolve to make creating polymorphic types with value semantics easier
- Thanks to Alex Stepanov, Howard Hinnant, and Dave Abrahams
- <http://sean-parent.stlab.cc/papers-and-presentations>
- Stepanov, Alexander and Paul McJones. *Elements of Programming*. Addison-Wesley Professional, 2009.



**Adobe**